

INDIAN COUNCIL OF FORESTRY RESEARCH & EDUCATION

P.O. NEW FOREST, DEHRADUN - 248 006



TENDER DOCUMENT

No. 4-2(Vol-IX)/IT/ICFRE/2016-17/19 Dated: 20-01-2017
(Against this office tender Notice No. 4-2 (Vol-IX)/IT/ICFRE/2016-17/19)

FOR UPGRADATION (THROUGH BUYBACK), OPERATION AND MAINTENANCE OF EXISTING & UPGRADED LOCAL AREA NETWORKS (LANs) HARDWARE/SOFTWARE FOR FIVE YEARS

The interested companies / firms or their authorized representatives are invited in the pre-bid conference, for their suggestions in terms and conditions / technical specifications and clarification thereof. However, the Indian Council of Forestry Research and Education (ICFRE) is not bound to accept any / all suggestions and the decision of the ADG (IT&FS), ICFRE shall be final in this regard.

A revised tender document / corrigendum, containing the changes, if any, shall be available at www.icfre.gov.in of ICFRE as well on <https://eprocure.gov.in> free-of-cost, within a week after the Pre-bid conference for bid preparation and submission by the tenderer.

Bhand
Asst. Director (Personnel)
Indian Council of Forestry Research and Education
P.O. New Forest, Dehradun

CONTENTS

SNo	Particulars	Page No
1	Tender Schedule	4
2	Definitions	4
3	Scope of Work	4
4	Period of Maintenance Contract	6
5	Performance Security	7
6	General Terms and Conditions	7
7	The Contract	8
8	Payment Terms	9
9	Service Level Agreement	10
10	Arbitration	12
11	Force Majeure	13
12	Preparation and submission of Proposal	13
13	Proposal Evaluation	16
Schedule I	Format of Curriculum Vitae (C.V.) for proposed key staff	18
Schedule II	Assignment of Similar Nature & Magnitude Successfully Completed during last 3 years	19
Schedule III	Particulars of the Firm/Company	20
Schedule IV	Bid Proposal Sheet	22
Schedule V	Performa for Performance Security	24
Schedule VI- A,B,C	Proposed LAN topology for each ICFRE Institutes, List of Equipment to be supplied for Upgradation of LAN, List of Equipment to be Considered for Maintenance and List of switches to be replaced under buyback.	26
Schedule VII	List of Locations with Detailed Address	43
Schedule VII-A	Location wise requirement of Support Type	44
Schedule VIII	Location wise Address and Contact Details of Fault Repairing Centre to be Provided by the firm	45
Schedule IX- A,B	Financial Proposal for Upgradation (Through Buyback), Operation AND Maintenance OF Existing & UPGRADED LOCAL AREA NETWORK (LAN) HARDWARE/SOFTWARE FOR FIVE YEARS	46
Annexure 1	Specification for newly proposed switches	53
Annexure 2	Details of qualifying documents	55
Annexure 3	Details of technical documents	56

 Anand
 Anand Director General
 P.O. - [illegible]
 P.O. - [illegible]

Notice Inviting e-Tender



INFORMATION TECHNOLOGY DIVISION

INDIAN COUNCIL OF FORESTRY RESEARCH AND EDUCATION
P.O New Forest- Dehradun

(An Autonomous Body of Ministry of Environment, Forests and Climate Change, Government of India)

Tender No: 4-2(Vol-VI)/IT/ICFRE/2016-17/ 19 Dated 20-01-2017

E-Tender Notice

For Upgradation (through Buyback), Operation and Maintenance of Existing and Upgraded LANs Hardware/Software at Indian Council of Forestry Research and Education (ICFRE) Head Qtrs and its Institutes / Centres across the country for a period of five (5) Years.

e-Tenders are invited by ICFRE, Dehradun from the eligible and reputed firms/companies having experience in Upgradation (through Buyback), Operation and Maintenance of Networking Equipment and other Hardware. The detailed specifications of the equipments to be supplied and installed are listed in the Schedule VI-A and those old equipments to be bought back by the selected firm/company are listed in the Schedule VI-C. The selected firm/company has to provide Operations and Maintenance (a Comprehensive Maintenance Contract) for a period of five (5) years after commissioning of the LAN Hardware/Software as per Schedule VI-A and Schedule VI-B at the locations given in Schedule VII.

ADG (IT&FS)
ICFRE, Dehradun

1. **TENDER SCHEDULE**

Events	Date/Time	Venue
Published Date	25.01.2017 12.30 PM	ICFRE website and Central Public Procurement (CPP) Portal
Bid document download/Sale start date	25.01.2017 01.30 PM	CPP Portal
Pre-bid Meeting	17.02.2017 10:00 AM	Board Room, ICFRE Head Qtr, Dehradun
Bid submission start date	23.02.2017 11.00 AM	CPP portal
Bid submission end date	10.03.2017 11.00 AM	CPP portal
Opening date of technical bids	10.03.2017 11.30 AM	Online
Opening date for Financial bids	17.03.2017 11:00 AM	Online

2. **DEFINITIONS**

- a) **Indian Council of Forestry Research and Education (ICFRE)** means the organisation as a whole including ICFRE Hqtrs. and its Institutes / Centres as listed in **Schedule VII**.
- b) **ADG (IT&FS), ICFRE** mentioned herein means the Assistant Director General (Information Technology & Forestry Statistics), ICFRE Dehradun representing ICFRE; and his official successors, nominees as may be designated by ICFRE from time to time.
- c) **Locations** mentioned hereunder means the locations of ICFRE HQtrs., its Institutes /Centres as detailed in **Schedule VII**.
- d) **Components / equipment / system** mentioned hereunder included ROUTERS, SWITCHES / HUBS, LAN-EXTENDERS, MODEM at all the locations listed in **Schedule VII** and the location wise equipment is listed in **Schedule VI-B**.
- e) **EMD** means Earnest Money Deposit
- f) **PBG** means Performance Bank Guarantee
- g) **SLA** means Service Level Agreement as per the parameters laid down in this document.
- h) **Firm** means a duly registered Firm or Company registered under Indian Laws as such, and bidding for this tender.

3. **SCOPE OF WORK FOR THE FIRM**

- a) The Indian Council of Forestry Research and Education (ICFRE), Dehradun, Uttarakhand invites tenders in the prescribed format for Upgradation (through Buyback), Operation and Maintenance of Existing and Upgraded LAN Hardware/Software (Equipment comprising of ROUTERS, SWITCHES, LAN-EXTENDERS, MODEM etc.), at various regional institutes as per the locational details given in **Schedule VII**. **The purpose of Upgradation is to have**

 Asstt. Dir. (I.T. & FS)
 Indian Council of Forestry Research and Education
 P.O. - New

all intelligent devices and to replace the old switches / hubs to meet the requirements of latest ICT (Information and communications technologies) for a robust Local Area Network (LAN) across ICFRE.

- b) The selected firm/company through this tender has to Upgrade (through Buyback), the operation & maintain the switches, network equipment and existing hardware, and also upgrade the existing LAN infrastructure of ICFRE Head Qtrs and its institutes/centers as per **Schedule VI-A**.
- c) All equipment; including material to be supplied, installed and commissioned by the selected firm shall be internationally reputed brand and new - for items to be supplied under this tender given in **Schedule VI-A**. The firm shall supply from the same brand/OEM for every category of item (for example - all switches from the same OEM) across the Institutes (Centre). **The supplied switches should support a feature that ICFRE can easily monitor the activity of each switch across ICFRE Virtual Private Network (ICFRE-VPN) and network switch topology can be generated using these switches.** A brochure should be furnished supporting the features from OEM.
- d) The products supplied through this tender shall not be de-supported or declared end of life within next 5 (five) years. A certificate to that effect should be furnished from OEM. All equipment supplied shall conform to the codes, standards and regulations applicable and benefit from the usual manufacturer's guarantee.
- e) For products supplied through this tender, the selected firm shall provide the comprehensive maintenance support till the end of the contract (for switches, network equipment and software licenses).
- f) The switches, network equipment and its software licenses (if any) have to be configured as per requirements of ICFRE and its Institutes/Centers as given in **Schedule VII**.
- g) All switches supplied under this tender shall be managed switches and all uplinks to be done with Giga ports with UTP CAT 6A cable as uplink media.
- h) The firm has to do the media access control address (MAC address) binding of I/O ports of connected devices at ICFRE Head Qtr and its Institutes/Centres. The punching and replacement of I/O boxes to be done by the firm whenever necessary.
- i) The firm has to replace the defective I/O Boxes, if any, punching of the same, cable labelling and rationalization by reordering the messy cabling, if any, at any locations as given in Schedule VII.
- j) The firm shall provide support for configuration of switches, network equipment and its software licenses (if any), and existing LAN hardware as and when needed by ICFRE (Head Qtr) and its institutes/centres.
- k) The firm shall provide support for operations and maintenance of switches, network equipment and its software licenses (if any), and existing LAN hardware by following SLAs as specified in this tender document.
- l) The firm shall co-ordinate with stakeholders of ICFRE and its institutes/centers for resolving connectivity problems w.r.t network equipment and related hardware which affects the performance and/or operation of servers and workstations at locations specified in **Schedule VII**.
- m) The firm shall co-ordinate, if necessary, with OEM to support for configuration issues, hardware, replacement etc.
- n) The firm shall provide patches/upgrades of Network Equipment, Operating Systems during entire period of the contract without any extra cost to ICFE (Head Qtr) and its institutes/centers by abiding to SLAs as specified in this tender document.



Asstt. Director
Institutional Development
Research & Evaluation
P.O.-New Forest, Bhubaneswar

- o) Maintenance Contract shall be comprehensive which not only provides free replacement of defective and burnt out part(s) (of LAN equipment/system which were purchased/installed from calendar year 2010 onwards) but also its regular corrective and preventive services.
- p) The firm shall provide new and original spare parts, assemblies and sub-assemblies in place of such items, which develop defects/suffer breakdown during the period of Maintenance Contract. These replacement parts shall be the property of ICFRE after installation. Released components after replacement would always be firm's property.
- q) Interchanging of data communication equipment from one location to other location shall be done- under intimation to IT Division, ICFRE with details and reasons-when and where the situation demands for operation/maintenance of network.
- r) The firm shall post qualified and certified resident Service Engineers / Technical Support on call basis, as per the detailed requirements given in **Schedule VII-A**.
- s) As part of Maintenance Contract, the Resident Service Engineer shall carry out quarterly preventive maintenance, with prior appointment with the authorized representative of the respective location listed in **Schedule VII**.
- t) The replacement of the components shall be done in the premises at all the locations given in **Schedule VII**, including ICFRE Headquarters at Dehradun. In case of any offsite service requirements of equipment(s) prior written permission from the authorised representative of the respective location shall be mandatory.
- u) The firm shall keep fairly good stock of components at the site with the resident engineers so as to minimise the downtime of machines/equipment.
- v) Spare management of all data communication equipment like Routers, Switches of different makes for maintaining uptime requirement shall necessarily be arranged by the firm.
- w) The Maintenance Contract covers all the location wise equipment listed in **Schedule VI-A and Schedule VI-B**. Router cables, power supply and other cables of different makes etc. are to be maintained and replaced by the firm.
- x) It shall be mandatory on the part of the firm to hand over all the equipment under the contract in working condition at the time of end / termination of the contract, otherwise the equipment found faulty, shall be made good at the cost of the firm, by arranging its repair from external agencies. **The accrued cost on such repairs, if any, shall be deducted from the liable payments / Performance Bank Guarantee.**
- y) The firm shall submit monthly maintenance report to the authorized representative of respective locations. The firm shall arrange the requisite documentation and maintain necessary records, including photos of the rack etc. **The firm shall ensure the communication of quarterly preventive maintenance reports duly signed and stamped by the Director of respective institute for processing the quarterly payment during the period of Maintenance Contract.** In the event of non receipt of such quarterly preventive maintenance reports, the quarterly payment shall not be processed. The firm shall submit a copy of the document / maintenance records to the IT Division, as and when required for reference.

4. PERIOD OF MAINTENANCE CONTRACT

- a) Initially the contract shall be for **five years** subject to satisfactory fulfilment of the obligations laid down in the terms and conditions and contract of the tender document. The contract may be extended for the period of two years if the services are found satisfactory.

Asstt. Director for Computing
(I.T. and Policy) Ministry of Research and Forestry
P.O. New Forest, Dehradun

b) The date of initiation of the contract will be the date of signing of the contract.

5. PERFORMANCE SECURITY

- a) To ensure due performance of the contract, Performance Security in the form of Performance Bank Guarantee (PBG) from a Nationalised Bank, needs to be submitted by the successful bidder. The successful bidder shall have to submit a PBG of 10% of the total contract value. The PBG should be valid for a period of six months beyond the contractual obligations. In case, the contract is extended for further two years, the bidder will extend the validity of PBG before its expiry. The PBG shall be submitted in the format given in **Schedule V**.
- b) The non adherence to the terms and conditions given herein and in subsequent Memorandum of Agreement with the successful bidder shall amount to breach of contract and may lead to forfeiture of Performance Security amount in full or in part.
- c) ICFRE may forfeit the Performance Security fully / partially against any kind of recoveries to be made from the firm for non performance / mandatory repairs during and at the end of the contract.
- d) Non-fulfilment of SLAs may further invite forfeiture of Performance Security amount partially or in full.
- e) No interest shall be payable on the Performance Security amount by ICFRE.

6. GENERAL TERMS AND CONDITIONS

- a) Bidders are advised to study the tender document carefully. Submission of bids shall be deemed to have been done after careful study and examination of the tender document with full understanding of its implications.
- b) Any clarifications from ICFRE or any change in requirement shall be posted on www.icfre.gov.in and <https://eprocure.gov.in>. It shall be the sole responsibility of the bidder to check for any changes of aforementioned website before submitting the bids.
- c) ICFRE shall not be responsible for non-receipt / non-delivery of the bid documents due to any reason whatsoever.
- d) The bidder shall indicate the complete address of the Firm and work along with the name(s) of the contact person(s) and their telephone / Fax / Mobile Nos.(s) and other particulars as per **Schedule III**.
- e) An EMD of Rs. 100,000/- (Rupees One Lakh only) in the form of Fixed Deposit Receipt or Bank Guarantee drawn on any nationalised bank in favour of D.D.O., ICFRE payable at Dehradun shall be deposited as a part of qualifying bid of the Tender. The EMD shall be returned to bidders upon finalisation of the successful bidder and award of the contract. No interest shall be payable on the EMD by ICFRE. The EMD submitted by the bidder may be forfeited at any stage, if the bidder backs out of the bidding process after submitting the bids to ICFRE or fails to accept the work order issued to the firm.
- f) The bid prices for Comprehensive Maintenance Contract be quoted in the attached BOQ1.xls and **Schedule IX-A & B** only.
- g) The bidders shall be allowed to inspect the networking equipment (mentioned in **Schedule VI-B and Schedule VI-C** of this tender document) between 9.30 AM to 5.00 PM on all working days before the last date of submission of the tender. The firm shall raise a formal request for the purpose to ADG (IT&FS) for ICFRE Head Qtrs. or to Director of respective institute / centre. ICFRE shall not be responsible for any cost incurred on such inspections.

Beard

Asst. Director
Indian Council of Forestry
Research & Training
P.O.-New Forest, Dehradun

- h) Acceptance of the bid shall be communicated to the successful bidder by a formal Letter of Intent (LoI).
- i) **Within thirty days** of issue of Letter of Intent (LoI) the successful bidder shall :
- Sign a contract with ICFRE for 'Upgradation (through Buyback), Operation and Maintenance of Existing and upgraded LANs Hardware/Software for the period of five years', on a stamp paper of Rs. 100/- to be furnished by the firm.
 - Furnish a Performance Security (as per the Schedule V) issued by a Nationalised Bank in favour of DDO, ICFRE, Dehradun, having validity of six months beyond the date of expiry of the Contract, for an amount equivalent to 10% of the total contract value.
 - Furnish a duly acknowledged list of hardware taken over under Maintenance Contract by the firm as a part of the agreement.
- j) Immediately after finalisation of the Contract, the vendor shall start Operation and Maintenance and carry out the Upgradation (through Buyback) of equipments as per Schedule within 120 days of the contract coming in force. Subsequently authorised representatives of ICFRE at the respective locations jointly with the vendor shall do marking on all equipments that are to be considered for the Maintenance contract and are listed in Schedule VI-A and Schedule VI-B and be taken over by the firm.
- k) The bidder shall indicate the location wise complete address of the Firm and Service Centre along with the name(s) of the contact person(s) and their telephone / Fax / Mobile Nos.(s) and other particulars as per the Performa at Schedule VIII.
- l) Commencement of Assignment shall be as per the Memorandum of Agreement (Contract) formalized with the successful firm.
- m) The Vendor shall maintain and use genuine/OEM components for replacement wherever needed and the vendor shall not use sub-standard/duplicate components under any circumstances. The replacement of equipment may be with same OEM or in case it is not possible to replace with same OEM, then with OEM which has maximum number of switch/LAN equipment.

7. THE CONTRACT

- a) The General Terms and Conditions and the Service Level Agreement (SLA) shall form the part of the contract.
- b) If any part of the contract does not correspond or agree with any other part, or if any question arises as to the meaning of the terms of the contract or as to the performance of the work, ADG (IT&FS), ICFRE shall determine the matter and his/her decision shall be final and binding upon the parties to the contract.
- c) The contract when executed by the parties hereto shall constitute the entire contract between the parties in connection with the works covered, and shall be binding upon the parties hereto or upon either of them unless the said modification shall be in writing and duly executed by ICFRE and the firm.
- d) The contract shall not be assigned or sublet in whole or in part by the firm.
- e) The Assistant Director General (IT&FS), ICFRE shall have the powers to cancel the contract at thirty days notice, if the services provided by the firm are found unsatisfactory or for any other violations of the contractual obligations on the part of the firm and may lead to forfeiture of Performance Security in part or in full.

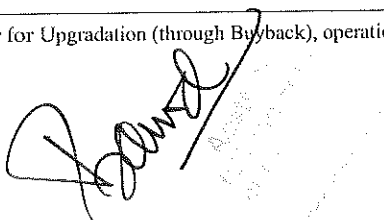
A handwritten signature in black ink is written over a circular official stamp. The signature is cursive and appears to read 'Rajendra'. The stamp is partially obscured by the signature and contains some illegible text.

- f) No variation in or modification of the terms of the contract shall be made except by written amendment signed by both the parties i.e. the successful bidder and the ADG (IT&FS), ICFRE.
- g) The contract shall not be deemed an asset in any form by the firm.

8. PAYMENT TERMS

- i) The ICFRE will pay 90% (ninety percent) of the cost of new switches after adjusting the price of old switches/hubs through buy back after successful installation and commissioning at all project locations. The remaining 10% (ten percent) will be paid in twenty instalments quarterly over the contract period.
- ii) The firm shall submit a separate bill for Upgradation (Buyback) along with installation reports signed by respective Incharge IT Cell of ICFRE Institutes / Centres after completion of work to the ADG (IT&FS), ICFRE. The firm shall also submit the bill in triplicate on completion of each quarter during Operation and Maintenance to the ADG (IT&FS), ICFRE.
- iii) The firm shall ensure the communication of Preventive Maintenance Reports / Service Call Reports of the hardware/software in respect of the equipment under contract on quarterly basis through the Directors of the respective Institute and signed and stamped by the respective Directors of the Institutes.
- iv) Payment shall be released after scrutiny of these reports and the amount for penalty for unsatisfactory maintenance or violations of contract conditions, if any, shall be deducted which shall be binding on the firm. The records maintained by the firm may be called for the purpose of scrutiny of the bills.
- v) The taxes should be indicated separately in the bid and will be payable as per the Government Law. Any change in government taxation policy will be applicable.
- vi) The ICFRE shall deduct such taxes, duties and any other statutory levies imposed by the Government on such charges as may arise from the implementation of the contract agreement.
- vii) The Assistant Director General (IT&FS) reserves the right of addition and exclusion of equipment in the Maintenance Contract, as and when required, under intimation to all concerned. The quarterly payment shall be made on the basis of actual equipment maintained and any withdrawal / addition of equipment shall be given due consideration and the payment adjusted accordingly.
- viii) The payment is subject to TDS as per Income Tax Rules / Laws.
- ix) No legal proceedings to enforce any claim and no suite arising out of this contract shall be instituted except in a court of competent jurisdiction over Dehradun, Uttarakhand.
- x) If any payment is made in excess, it shall have to be refunded by the successful bidder/vendor to the ICFRE immediately as and when asked for.
- xi) The successful bidder/vendor shall not proceed against ICFRE in the event of late payment due to unforeseen reasons.
- xii) If the firm violates any of these terms and conditions, the Performance Security shall be liable for forfeiture, wholly or partly, as decided by Assistant Director General (IT&FS), ICFRE and the contract may be terminated.

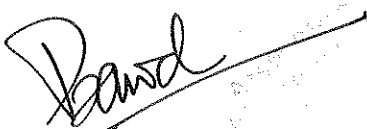

9. **SERVICE LEVEL AGREEMENT (SLA)**

- a) The type of requisite supports viz., Resident Engineer based and Call Basis Technical Support shall be provided by the firm as per the requirement listed in **Schedule VII-A**.
- b) **In case of Call Based Technical Support (through fault reporting centre)**
 - i) Under this arrangement the firm shall provide support to the respective institute / centre on call basis as and when approached for.
 - ii) The firm should provide fault-reporting centres at all the locations listed in **Schedule VII** with their address and contact details as per **Schedule VIII**.
 - iii) The fault reporting centres shall take calls from the users over Telephone/Cell Phone/FAX/eMail provided by the firm for rendering an immediate service, which should be available 24x7.
 - iv) If the firm feels to open additional fault reporting centre to comply with fault within the permitted time, the firm is free to do at no extra cost to ICFRE.
- c) **In case of Support through Resident Engineer**
 - i) The firm shall post qualified and certified resident Service Engineers as per the detailed location wise requirement given in **Schedule VII-A**.
 - ii) The resident service engineers shall report to the respective Head / Incharge of Information Technology Division/Cell of ICFRE Hqtrs. or its Institutes on all working days from 9:00 a.m. to 5:30 p.m. The resident engineer may be available in office beyond office hours or on holiday in case the situation demands or any other reasons without extra cost.
 - iii) The firm shall post engineers after assessing the requirement at ICFRE. The engineers shall be responsible for maintenance and management of items as per items listed in **Schedule VI-A** and **Schedule VI-B**.
 - iv) In addition to this the firm must have a local backup support of a qualified / certified Network Personnel, to take responsibilities of excessive workloads and be ready to provide expertise, in case of need.
 - v) The resident engineer must be equipped with maintenance kits comprising of tool box, diagnostic software and hardware and any other tools and tackles required for carrying out such services.
 - vi) The resident engineer once deputed shall be changed only with the prior permission of the Head/Incharge of Information Technology Division/Cell, of ICFRE Institutes. Frequent changes of the engineer may not be allowed.
 - vii) The resident engineer shall be granted only two day leave on monthly basis and the absence beyond permissible leave period shall amount to a default and would invite the penalties as defined before.
 - viii) The calls shall be assigned to the deputed resident engineer by the users / Head of the respective IT Cell/ Division of the respective institute.

The Service Level Parameters as laid down below must be complied by the firm in both the cases viz.; Call Based Technical Support and Support through Resident Engineer



- d) **Response Time:** The firm has to ensure that all the complaints lodged by the user / user group are attended to and rectified within the shortest possible time.

Support through Resident Engineer	First Level diagnostics	4 hours
	Resolution Time	24 hours
Call based Technical Support	First Level diagnostics	24 hours
	Resolution Time	48 hours

The firm should be in a position to supply standby equipment and/or accessories, if the equipment/accessory of these locations goes down, in order to restore the network services.

e) **Up Time**

- i) The firm must ensure up time of at least 98% of all individual equipment being offered under this tender.
- ii) Non-availability of standby system shall be considered to be as down time and monitored as per SLA.
- iii) The up time shall be calculated on monthly basis.

f) **Down time**

- i) Down time is defined as duration for which system as whole or any part is not available for the purpose it is installed.
- ii) Non-availability of standby system shall not be counted for down time.
- iii) The down time shall be reckoned after 4 hours from time the firm's representative has been informed by means of fax, telegram, telephone or any other method from the fault reporting centre.

g) **Working hours**

Working hours for the system shall be considered as 24 hours per day for all 7 days of week.

h) **Penalty applicable**

- i) If the complaint/call is not resolved within the resolution time-frame or no standby equipment(s) is/are provided by the firm, penalty shall be charged as per the rate tabulated below:

Up to 1 day beyond the resolution time (24 hours)	Rs 1000/- per day
Beyond 3 day	Rs 2000/- per day per equipment involved shall be charged and deducted from the quarterly payment to be made to the firm
The absence of resident engineer shall invite penalties as below :	
Engineer not available up to 2 days	Rs 500/-
Engineer not available beyond 2 days	Rs 1000/- per day shall be charged and deducted from the quarterly payment to be made to the firm.

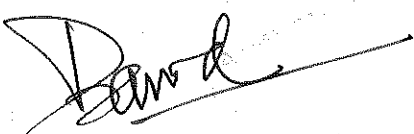

- ii) The unresolved calls due to absence of engineers shall not only invite the penalties against absence but also any penalty attributed to non functionality of equipment(s) as the case may be.
- iii) The penalty amount may be considered to be waived off in full or part after the deduction by ICFRE in previous quarters, if the firm is able to justify its position with supporting bills for the work that is carried out and efforts made to comply with the SLAs. Such waiver will be included in the preceding quarterly payments and any considerations shall not be the right of the firm and shall solely rest at the discretion of the ADG (IT&FS), ICFRE.

i) Preventive Maintenance

The firm has to carryout preventive maintenance of all components / equipment under the contract on quarterly basis. The following Maintenance activities shall be carried out during the preventive maintenance, but not limited to the same:

- a) Checking of all Network equipment.
- b) Checking of routers/switches for proper configuration.
- c) Checking of the power supply, earthing, and connectivity to equipment and proper dressing of cables connected to network equipment.
- d) Monitoring the network-rack condition, temperature and other environmental conditions like dust, dampness etc. and coordinating with the assistance of passive network service provider for appropriate action
- e) Supervising cleaning of the equipment/accessories.
- f) Preventive Maintenance report has to be submitted as per the format prescribed by ICFRE, along with the digital photograph of location.
- g) Any other job related to servicing/maintenance as may be deemed fit from time to time.

10. ARBITRATION

Except where otherwise provided in the contract all questions and disputes whatsoever in any way arising out of or relating to the contract or otherwise concerning the work or the execution or failure to execute the same whether arising during the progress of the Maintenance Contract or after the completion or abandonment thereof shall be referred to the sole arbitration of the person appointed by the Director General, Indian Council of Forestry Research & Education, (DG, ICFRE) Dehradun on his behalf at the time of dispute. There shall be no objection to any such appointment that the arbitrator so appointed is an employee of ICFRE, or government servant or that he/she had to deal with the matters to which the contract relates or that in the course of his/her duties as an employee of ICFRE, or government servant, he had expressed views on all or any of the matters in dispute of differences. The arbitrator to whom the matter is originally referred being transferred or vacating his/her office or being unable to act for any reason, shall be replaced by another person as decided by DG, ICFRE, to act as arbitrator in accordance with the terms of the contract. Such person shall be entitled to proceed with the reference from the stage at which it was left by his/her predecessor. It is also a term of this contract that no person other than a person appointed by the Director General, ICFRE should act as arbitrator and if for any reason, that is not possible, the matter is not to be referred to arbitration at all.

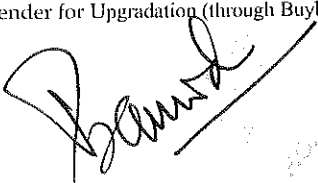

Subject as aforesaid, the provisions of the Arbitration and Conciliation Act 1996 or any statutory modifications or re-enactment thereof and the rules made there under and for the time being in force shall apply to the arbitration proceeding under this clause.

Services under the contract shall, notwithstanding the existence of any such dispute, question or controversy, continue during arbitration proceedings and no payment, due or payable by ICFRE or the firm shall be withheld on account of such proceedings unless such payments are the direct subject of the arbitration. Reference to arbitration shall be a condition precedent to any other action at law.

11. FORCE MAJEURE

- i) The performance of the obligations of either party under this Agreement is subject to Force Majeure.
- ii) If a Force Majeure situation arises, either party shall promptly notify to the other party in writing of such conditions and the cause thereof. Unless otherwise directed by ICFRE in writing, the vendor shall continue to perform its obligations under this agreement, as far as it is reasonably practical. Either party reserves the right to terminate this contract, without any additional liabilities to either party, if the Force Majeure period continues for more than 120 (One hundred and twenty days) at any of the locations given in **Schedule VII**.

12. PREPARATION AND SUBMISSION OF PROPOSAL

- i) Online bids are to be submitted under two Cover systems i.e. Cover 1 and Cover 2. All the pages of bid being submitted online must be signed and sequentially numbered by the bidder irrespective of nature of content of the documents before uploading.
- ii) The proposal should not have any interlineations or overwriting except as necessary to correct errors made by the concerned themselves, in which cases such corrections must be initialed by the person or persons authorised to sign the proposal. No Financial Bid items pertaining to this tender shall be submitted as part of the qualifying documents and/or in the technical bid stage. In case of violation of this condition, the bid shall be rejected and no communication shall be entertained in this matter.
- iii) The completed proposal must be submitted mandatorily online at CPP portal <https://eprocure.gov.in/eprocure/app> after going through the terms and conditions given thereof. The offers submitted by Fax/email/offline shall not be considered and no correspondence shall be entertained in this matter.
- iv) The tender is not transferable. No assignment and sub contracting is permitted.
- v) Validity of offer shall be 120 days from the last date of submission of bids.
- vi) While submitting the bid, the bidder shall be deemed to have read, understood and accepted all the terms and conditions stated in this Tender Document.
- vii) Assistant Director General (IT&FS), ICFRE reserves the right to reject any or all tenders without assigning any reasons.
- viii) The authority for the acceptance of the tender shall rest with the ICFRE. It shall not be obligatory on the authority to accept the lowest tender or any other tender and no tenderer(s) shall demand any explanation for the cause of rejection of his/their tender nor

shall ICFRE undertake to assign reasons for declining to consider or reject any particular tender or tenders.

- ix) Conditional tenders are liable to be rejected.

Cover 1. Technical Bid

A: Qualifying Documents

The qualifying documents should be uploaded in CPP portal: <https://eprocure.gov.in/eprocure/app> as indicated below. The authorized representative of Tenderer/Bidder has to sign the following documents on each page and the scanned copy of the documents in pdf format to be uploaded in CPP portal for qualifying in the bidding process:

- i) **Tender Fee**:-The tender form downloaded from CPP portal must include Rs. 5000/- (Rupees five thousand only) by crossed Demand Draft (DD) in favour of DDO,ICFRE, Dehradun payable at Dehradun as tender fee along with the tender submitted and the scanned copy of the same shall be uploaded in the CPP portal for records and reference. It is non-refundable. The hard copy DD towards Tender fee shall be send to ADG (IT & FS), Room No 31, ICFRE HQ, Dehradun-248006 and must be received on or before the last date/time of bid submission.
- ii) **EMD of Rs 1,00000/-** (Rupees One lack only) in the form of Fixed Deposit Receipt (FDR) drawn on nationalised bank in favour of DDO, ICFRE payable at Dehradun as EMD along with the tender submitted and the scanned copy of the same shall be uploaded in the CPP Portal for records and reference. The hardcopy of FDR towards EMD shall be send to ADG (IT & FS), Room No 31, ICFRE HQ, Dehradun-248006 and must be received on or before the last date/time of bid submission.
- iii) Documentary proof of having authorization from Original Equipment Manufacturer (OEM) for supply, installation and maintenance of network equipment and hardware/Manufacturers authorization form(s) - for items to be supplied under this tender given in **Schedule VI-A**.
- iv) Compliance to the specifications of the equipment given in the **Annexures 1 and 2** with supporting documents.
- v) The bidder should be a firm registered under Companies Act, 1956 / 2013 for the last five years.
- vi) The firm should have minimum annual turnover of Rs. 50 Crore during the last three financial years. (2013-14, 2014-15, and 2015-16) and it shall be a profit (profit after tax) making firm in at least two financial years between 2013 and 2016. **The annual turnover and P&L statements certified by a qualified Chartered Accountant are to be submitted.**
- vii) Existing Staff Strength of the firm, certified by the HR Head of the firm.
- viii) Copy of Firm's Registration / Partnership Deed / Power of Attorney.

- ix) Proof of Sales Tax / VAT / Income Tax Registration and proof of Sales Tax/ VAT/Service Tax paid for the latest assessment year.
- x) PAN/TAN allotted to the company by the Income Tax Department.
- xi) Clearance certificate from Income Tax department for last financial /assessment year or Income Tax Returns.
- xii) Authorisation for signing the tender documents/bids.
- xiii) Particulars of the Firm as per **Schedule III**.
- xiv) Bid Proposal Sheet as per **Schedule IV**.
- xv) Location wise Address and Contact Details of Fault Repairing Centre to be provided by the firm as per **Schedule VIII**.

Note: -

- a) The physical copy of DD/FDR towards tender fee and EMD respectively shall be submitted to the specified address on or before the last date/time of bid submission.
- b) The details of above Qualifying Documents may be mentioned in Annexure 2.

In absence of scanned and signed copy of required qualifying items as specified above - the tender would be considered as invalid.

B: Technical Documents

Technical documents should be uploaded in the CPP portal: <https://eprocure.gov.in/eprocure/app> as indicated below. The authorized representative of Tenderer/Bidder has to sign the following documents on each page and the scanned copy of the documents in pdf format to be uploaded in CPP portal as part of their Technical Bid:

- (a) The composition of the proposed staff/team to be engaged, the task, which would be assigned to each, and their timing.
- (b) Curriculum Vitae (C.V.) of proposed key staff as per Schedule I, with dully recent photograph by the proposed key professional and the document signed by authorized signatory. Key information should include: year with the firm, and degree of responsibility held in various similar assignments during the last 2 (two) years. Key professional staff of permanent nature possessing certifications of management/maintenance of networking hardware with sufficient experience shall be given preference.
- (c) Assignment of similar nature and magnitude successfully completed during last three years as per **Schedule II**. Enclose copies in work order and documents in support of rendering satisfactory services of the assignments detailed in the schedule. **Similar assignments undertaken in Government Organisations shall be given preference during evaluation.**
- (d) Certificate to the effect of having adequate Test and Measuring Instruments available on hand (own) and proposed to be inducted (own & hired to be given separately) for the subject work.
- (e) A Certificate to the effect that the company is in the business of Supply, Installation, Commissioning and Maintenance of Networking Equipment and Hardware for last five financial years with relevant documentary proof.
- (f) Completed particulars as per the Performa given in **Schedule VIII**.
- (g) Declaration in respect of Non-black listing of the firm.
- (h) Any other documents in support of technical details.

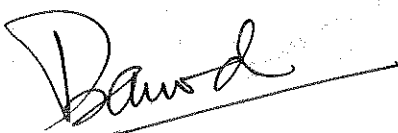

- (i) This tender document duly sealed and signed by the authorized signatory on every page and enclosed.
- a) In absence of scanned and signed copy of required technical bid items as specified above - the tender would be considered as invalid.
- b) The details of above Qualifying Documents may be mentioned in Annexure 3.

Cover 2: Financial Bid

- (a) The financial proposal must be submitted in the Schedule of financial bid in the form of BoQ1.xls separate for each item - through the CPP portal: <https://eprocure.gov.in/eprocure/app>.
- (b) The Performa under Cover 2, consisting of two separate Schedule IX- A, B
- (c) Full details of business terms and conditions, e.g. levies, octroi etc., if any other information relevant to the services may please be indicated clearly.
- (d) Prices shall be quoted in INDIAN RUPEES and without taxes. The taxes may be indicated separately in the bid and will be payable as per the Government Law. Any change in government taxation policy will be applicable.
- (e) TDS shall be made as per Income Tax Laws.

In absence of scanned and signed copy of required financial bid items as specified above - the tender would be considered as invalid.

13. PROPOSAL EVALUATION

The opening, checking, evaluation of bids at various stages shall be done by an evaluation committee appointed by the ICFRE. The following procedure shall be adopted in evaluating the proposals:-

a) Checking of Qualifying Documents

At first the Qualifying Bid shall be opened and checked for qualifying documents. Any disqualification in this qualifying round shall result in disqualification of the whole bid in toto.

b) Technical Evaluation

Only the Technical bids of the proposals qualifying in the first round (*Checking of qualifying documents*) shall be opened.

- (i) The firms/company which are ISO Certified for quality standards of Maintenance of LAN / Networking / related equipment and other peripherals shall be given preference in technical evaluation.

Technical evaluation shall be done based on the evaluation criteria and point system given below.

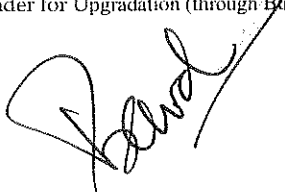

Technical evaluation criteria is given below:

a)	Firms with relevant experience (including similar jobs in hand) and ISO Certification for LAN Services, if any.	40
b)	Technical qualifications of the key staff proposed including their experience.	30
c)	The location and feasibility of fault booking centres as per requirements listed in Schedule VII-A and corresponding centres reported vide Schedule VIII	30
Total Score for Technical Proposal		100

Note: - The proposal must score at least 70 points out of 100 in the technical evaluation to be considered for financial evaluation.

c) Financial Evaluation

1. Financial bids of only those firms which pass both the qualifying document stage and the technical evaluation stage shall be considered for Financial evaluation. Financial evaluation will be done without taking taxes, levies etc. into account.
2. The evaluation committee shall determine if the financial proposals are complete and without computational errors. The total cost quoted in BOQ1.xls (**Total Cost of Financial Proposal as per Schedule IX-B**) shall be considered for financial evaluation.

d) Overall Evaluation

The firm which is having lowest financial quote shall be selected for the award of the contract for Supply, Installation, Commissioning and Maintenance Of Existing and Upgraded LAN Hardware/Software for 5 (five) years (extendable by two years beyond that, with mutual consent), subject to the conditions specified in this document.

Assistant Director General (IT&FS)

**FORMAT OF CURRICULUM VITAE (C.V.)
FOR PROPOSED KEY STAFF OF THE FIRM**

Proposed Position :
Name of Firm :
Name of Staff :
Profession :
Date of Birth :
Years with Firm : Nationality :
Membership of Professional Societies :

Details of Tasks Assigned :

Key Qualifications :

(Give an outline of staff member's experience and training most pertinent to task on assignment. Describe degree of responsibility held by staff member on relevant previous assignments and give dates and locations. Use up to half of a page).

Technical Qualification :

(Summarize specialized qualification of staff member, giving names of institutes organisations, attended and degrees, diploma, certificates obtained. Use up to quarter page).

Employment Record :

(Starting with present position, list in reverse order, every employment held. List all positions held by staff member since graduation, giving dates, names of employing organization, title of positions held and location of assignments. For experience in last ten years, also give types of activities performed and client references, where appropriate. Use up to three quarters of a page).

Signature of the proposed key staff be attested by the employer firm.

**CVs of different staff may please be given in different sheets in this format and
may please be attached herewith.**

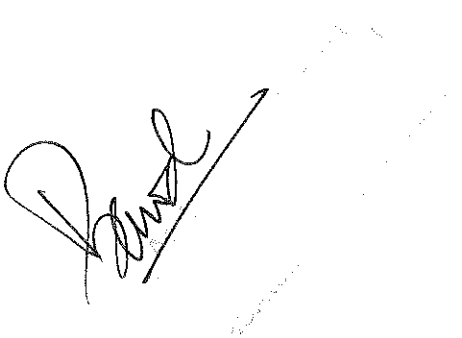

**ASSIGNMENT OF SIMILAR NATURE & MAGNITUDE SUCCESSFULLY COMPLETED
DURING LAST 3 YEARS BY THE FIRM**

Outline of recent experience on assignments of similar nature

Sl. No.	Name of assignment	Description and No. of equipment handled / maintained	Cost of assignment	Date of commencement	Date of completion	Was assignment satisfactorily completed (Attach documentary proof in support)	Address of organisation with Phone No. where assignment done
1	2	3	4	5	6	7	8

Note : The bidder may use separate sheet if required.

Signature of Bidder :.....

Name :

Seal :

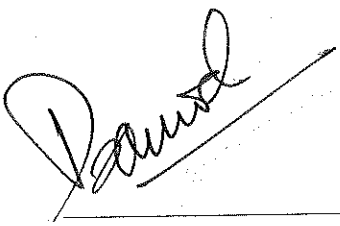

PARTICULARS OF THE FIRM

1. Name of the company/firm : _____
2. Head / Regd. Office Address : _____
 - a) Postal : _____
 - b) Fax. No. : _____
 - c) Telephone No.s (s) : _____
 - d) E-mail Address : _____
 - e) Website Address : _____
3. Former name of company/firm (if any) : _____
4. Dehradun Office Address : _____
 - a) Postal : _____
 - b) Fax. No. : _____
 - c) Telephone No.s (s) : _____
 - d) E-mail Address : _____
5. Type of Organization : Individual / Partnership / Incorporated
6. Service Centre Details :
 - a) Postal Address : _____
 - b) Contact Person (s) : _____
 - c) Fax No. : _____
 - d) Telephone No. (s) : _____
 - e) Mobile No. : _____
 - f) Working Hours : _____
 - g) E-mail Address : _____
7. (i) Year of establishment : _____
 - ii) Year in which network : _____

hardware maintenance
services started



8. Amount of Tender Fee deposited
- a) DD No. : _____
- b) Name of Bank : _____
- c) Amount : _____
- d) Date : _____
9. Amount of EMD deposited
- a) Fixed Deposit Receipt No.: _____
- b) Name of Bank : _____
- c) Amount : _____
- d) Date : _____
10. Period of validity of tender : _____
11. Details of supporting documents enclosed : _____
- _____
- _____
12. Name and address of the authorized signatory / contact person for this tender : _____
- _____
- _____
13. Whether letter of Authority for attending bid opening enclosed with tender ? : _____
14. Whether PAN certificate attached ? : _____
15. Sales Tax / VAT Regd. No. : _____
16. Whether the company/firm has ISO Certification ? : _____
- If yes / whether document attached in technical bid.

Signature of Bidder :.....

Name :

Seal :

Date : _____

Place : _____

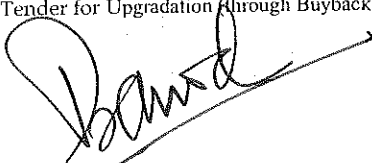

BID PROPOSAL SHEET

Tenderer's Proposal Reference No. & Date: _____

Tenderer's Name & Address : _____

Person to be contacted : _____

Designation : _____

Telephone No. E-mail: Fax No: _____

To:

The Assistant Director General (IT&FS)
 Directorate of Administration,
 Indian Council of Forestry Research & Education
 P.O. New Forest, Dehradun - 248006

Sub: Upgradation (through Buyback), operation and maintenance of existing and upgraded LANs HARDWARE/SOFTWARE for five years

Dear Sir,

1. We, the undersigned Tenderer(s), having read and examined in detail the bidding documents in respect of the above cited maintenance contracts as specified in the tender document.
2. All the prices mentioned in our proposal are in accordance with the terms as specified in the tender document. All the prices and other terms and conditions of this proposal are valid for a period of 120 calendar days from the last date of submission of bids.
3. We do hereby confirm that our bid prices include all taxes including Income Tax, Professional Tax and Service Tax etc.
4. We have studied the Clauses relating to Indian Income Tax and hereby declare that if any Income Tax, Surcharge on Income Tax and any other Corporate Tax is altered under the law, we shall pay the same.
5. We have enclosed the earnest money in the form of Fixed Deposit Receipt amounting to **Rs. 100,000/-** (Rupees One Lakh only), it is liable to be forfeited in accordance with the provisions of tender document.
6. We further declare that the prices stated in our proposal are in accordance with your terms & conditions in the tender document.
7. We confirm having submitted in qualifying data as required by you in your tender document. In case you require any further information /documentary proof in this regard before evaluation of our bid, we agree to furnish the same in time to your satisfaction.
8. We hereby declare that in case the contract is awarded to us, we shall submit the Performance Security equivalent to 10% of the total contract value in the form of Bank Guarantee as per terms of tender document.
9. We hereby declare that our proposal is made in good faith, without collusion or fraud and the information contained in the proposal is true and correct to the best of our knowledge & belief.

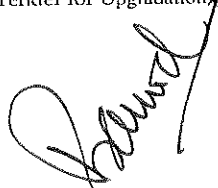

10. We understand that you are not bound to accept the lowest or any bid you may receive or to place part order or to reject any bid or to cancel the tender without assigning reason whatsoever.

Yours sincerely,

(Signature)

Date:
Place:

Name:
Designation:
Business Address: Seal

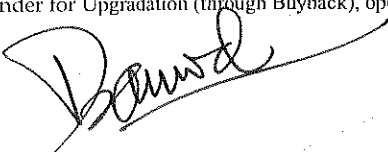
A handwritten signature in black ink, appearing to read 'D. B. D.' or similar, written over a horizontal line.

PROFORMA FOR PERFORMANCE SECURITY

(To be formulated on the Rs. 100/- non-judicial stamp paper by the issuing bank)

Ref : _____ Bank Guarantee : _____

Date : _____

Dear Sir,

In consideration of Indian Council of Forestry Research and Education, Dehra Dun (Hereinafter referred as the 'ICFRE', which expression shall, unless repugnant to the context of meaning thereof include its successors, administrators and assigns) having awarded to M/s _____ (hereinafter referred to as the vendor, which expression shall, unless repugnant to the context of meaning thereof include its successors, administrators and assigns) resulting in a Contract Valued for _____ hereinafter called the 'Contract' and the ICFRE having agreed to make an advance payment to the firm for performance of the above contract amounting to _____ (in words and figures) as an advance against Bank Guarantee to be furnished by the firm.

We _____ (Name of Bank) having its Head Office at _____ (hereinafter referred to as the Bank), which expression shall, unless repugnant to the context or meaning thereof, include its successors, administrators executors and assigns) do hereby guarantee and undertake to pay the ICFRE immediately on demand an or, all amount payable by the firm to the extent of _____ as aforesaid at any time upto _____ any demur, reservation, contest, resource or protest and / or without any reference to the firm. Any such demand made by the ICFRE on the Bank shall be conclusive and binding notwithstanding any difference between the ICFRE and firm or any dispute pending before any Court, Tribunal, Arbitrator or any other authority. We agree that the guarantee herein contained shall be irrevocable and shall continue to be enforceable till the ICFRE discharges this guarantee.

The ICFRE shall have the fullest liberty without affecting in any way the liability of the Bank under the Guarantee, from time to time to vary the advance or to extend the time of performance of the Contract by the firm. The ICFRE shall have the fullest liberty without affecting this guarantee, to postpone from time to time the exercise or any powers vested in them of any right which they might have against the vendor and to exercise the same at any time in any manner, and either to enforce or to forbear to enforce any covenants, contained or implied, in the Contract between the ICFRE and firm any other course or remedy or security available to the ICFRE. The bank shall not be relieve of its obligations under these presents by any exercise by the ICFRE of its liberty with reference to the matters aforesaid or any of them or by reason of any other act or forbearance or other acts of omission or commission on the part of the ICFRE or any other indulgence shown by the ICFRE or by any other matter or thing whatsoever which under lay would but for this provision have the effect of relieving the Bank.

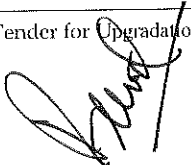

The Bank also agrees that the ICFRE at its option shall be entitled to enforce this Guarantee against the Bank as a principal debtor, in the first instance without proceeding against the vendor and notwithstanding any security or other guarantee that the ICFRE may have in relation to the firm's liabilities.

Notwithstanding anything contained herein above our liability under the guarantee is limited to _____ and it shall remain in force upto and including _____ and shall extend from time to time for M/s _____ on whose behalf this guarantee has been given.

Dated this day of _____ 201__ at _____

Signature & Seal of Authorised Signatory of Bank

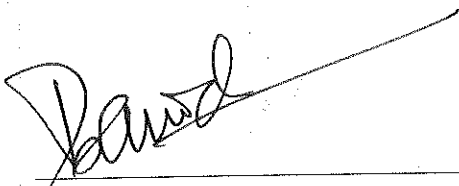
A handwritten signature in black ink, appearing to read "David", written over a horizontal line.

I. The proposed LAN topology for each Institute/Centre as illustrated in the diagrams for upgradation is given below:

(i) Proposed LAN topology for ICFRE Hqrs., Dehradun

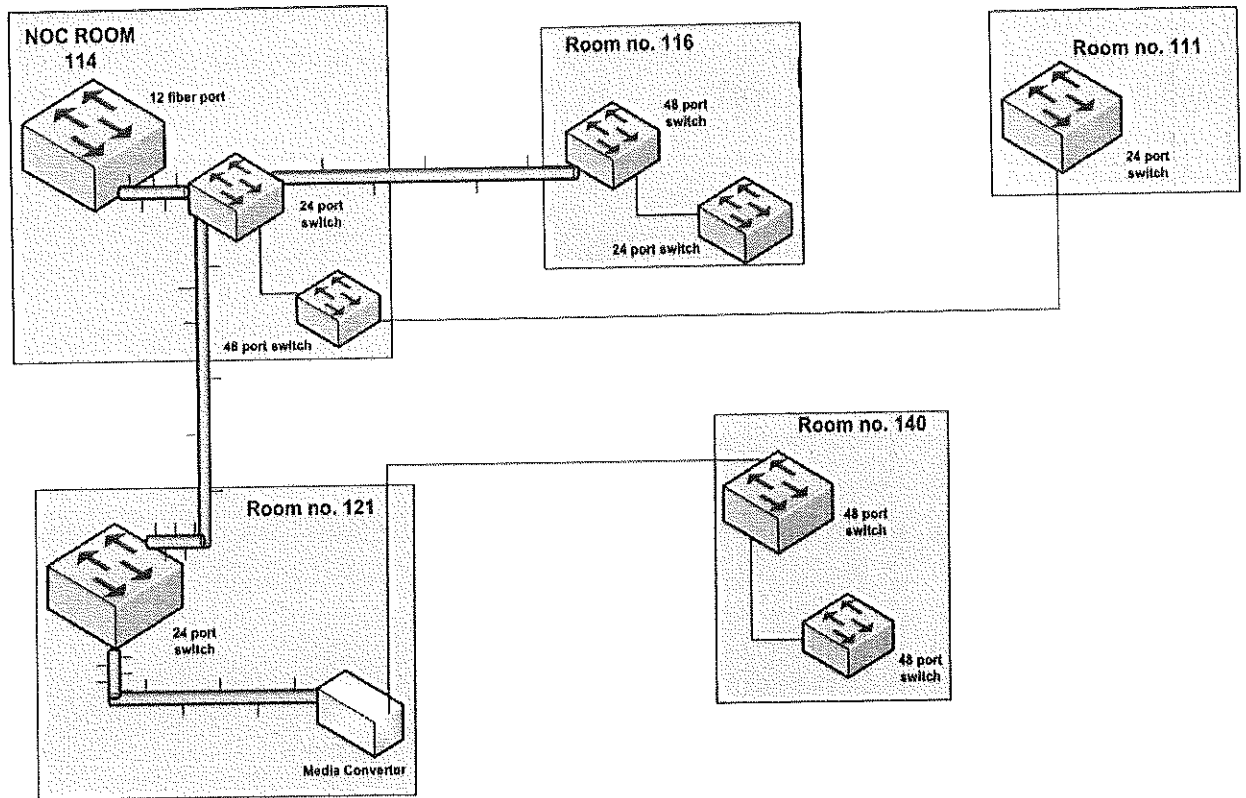

ICFRE HQ SWITCHES

(ii) Proposed LAN topology for IFGTB, Coimbatore

Proposed LAN Up gradation. IFGTB

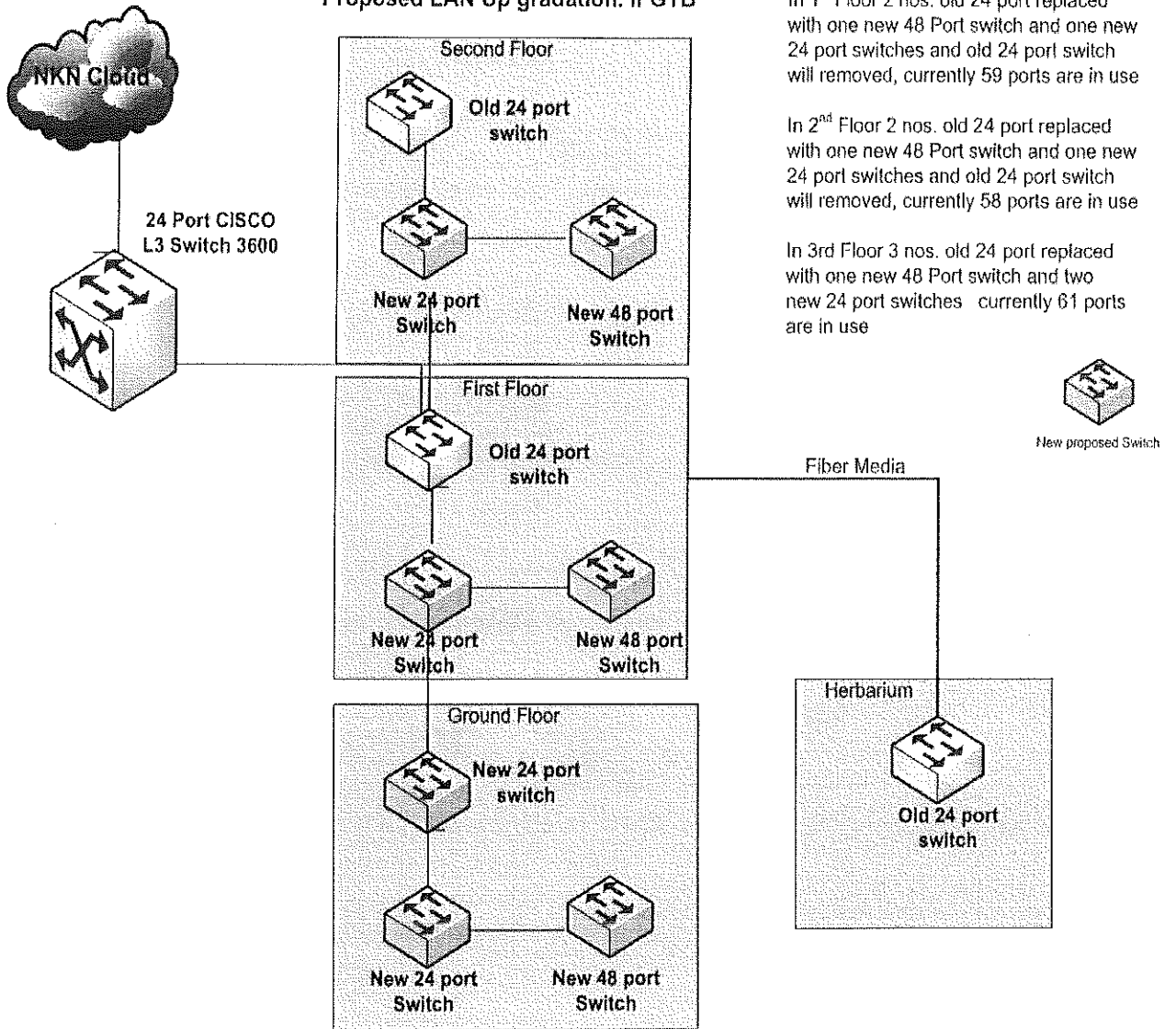

David

(iii) Proposed LAN topology for IFP, RANCHI

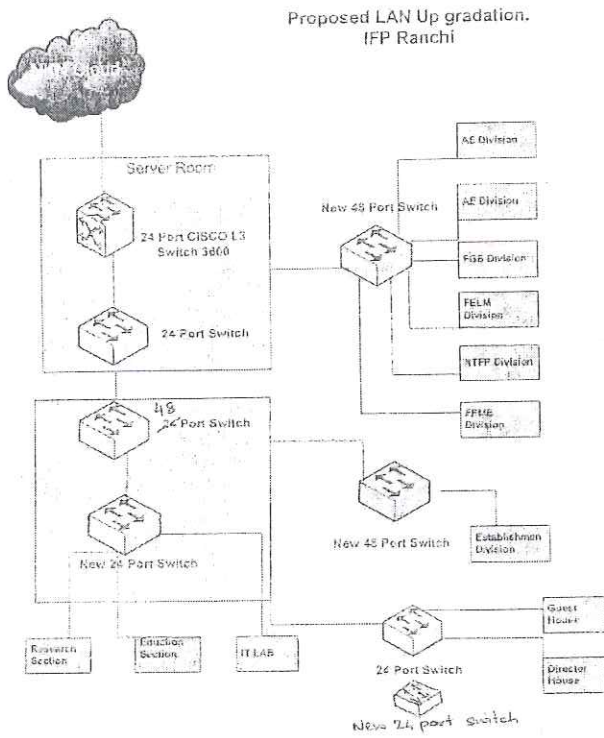

New 24 port Switch will be installed and connected with Research Section, Education Section and IT LAB by replacing all the HUBS

New 48 port switch will be installed and connected with AE Division, FGE Division, FELM Division, NTFP Division and FPME Division by replacing all the HUBS

New 48 Port switch will be installed and connected with Establishment Section by replacing two DES 101ED Switches



[Handwritten signature]
 28/01/2012

(iv) Proposed LAN topology for HFRI, Shimla

Proposed LAN Up gradation.
HFRI SHIMLA

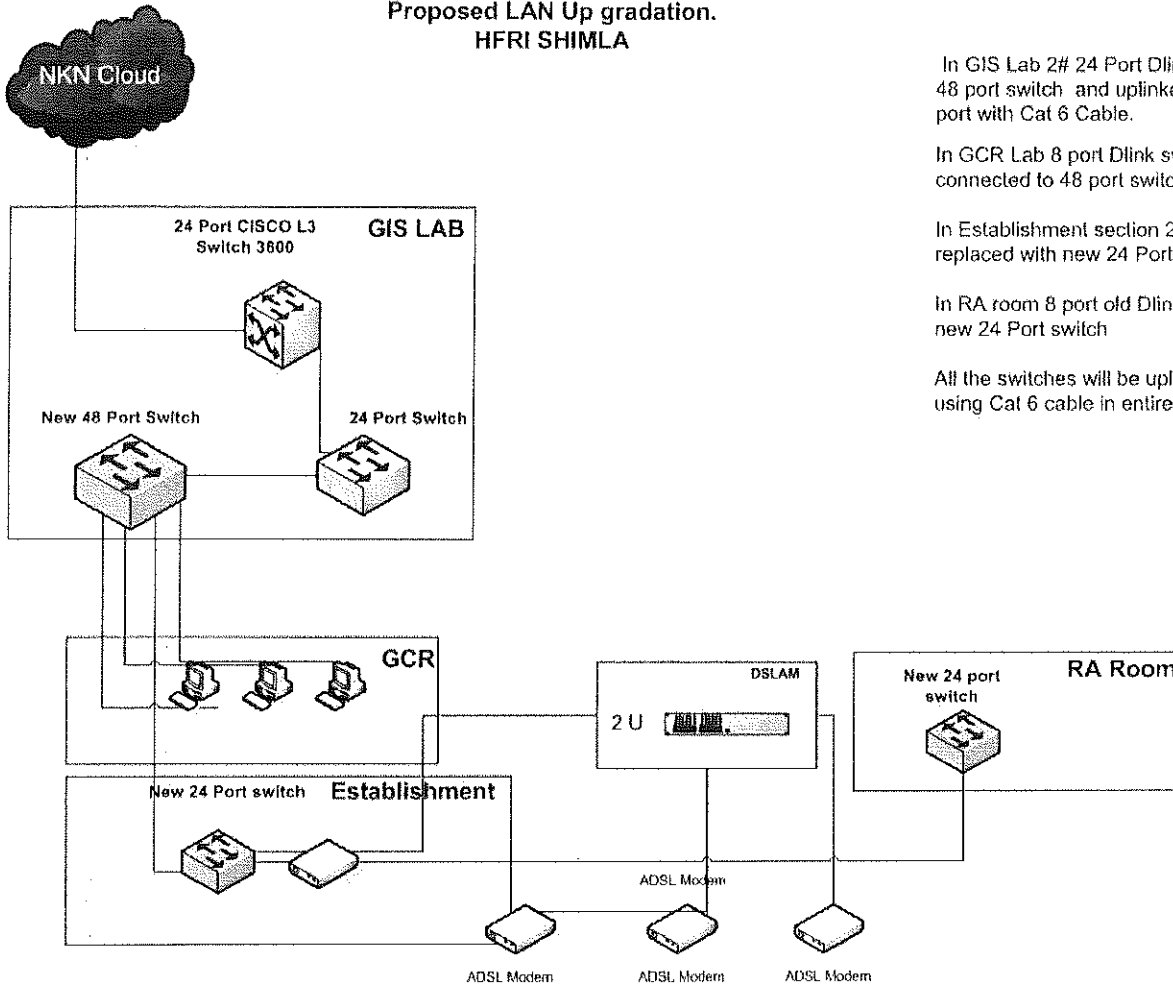

In GIS Lab 2# 24 Port Dlink switch replaced with 48 port switch and uplinked both side with Giga port with Cat 6 Cable.

In GCR Lab 8 port Dlink switch is removed and connected to 48 port switch from the GIS LAB

In Establishment section 24 port old Dlink switch replaced with new 24 Port switch

In RA room 8 port old Dlink switch replaced with new 24 Port switch

All the switches will be uplinked with Giga port using Cat 6 cable in entire up gradation



Bhand

(v) Proposed LAN topology for AFRI, Jodhpur

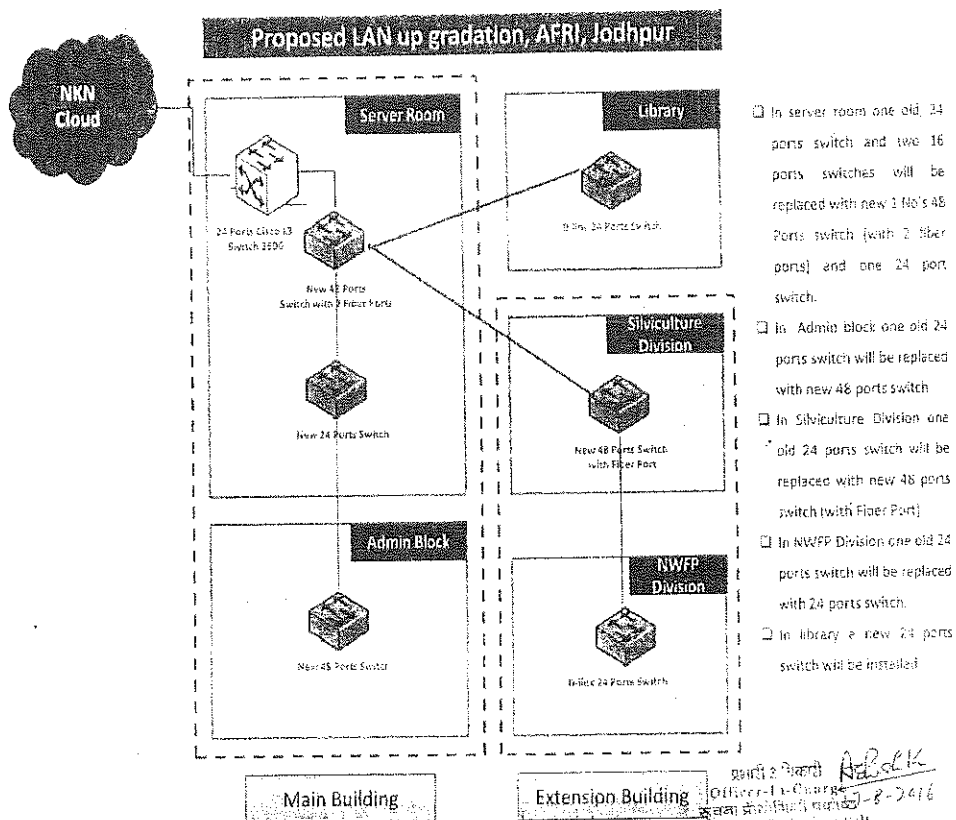

08/08/2016
 Officer-In-Charge
 Information Technology
 AFRI, Jodhpur
 08-2016
 DIRECTOR
 AFRI, JODHPUR

[Handwritten signature]

(vi) Proposed LAN topology for RFRI, Jorhat

Proposed LAN Up gradation.
RFRI Jorhat

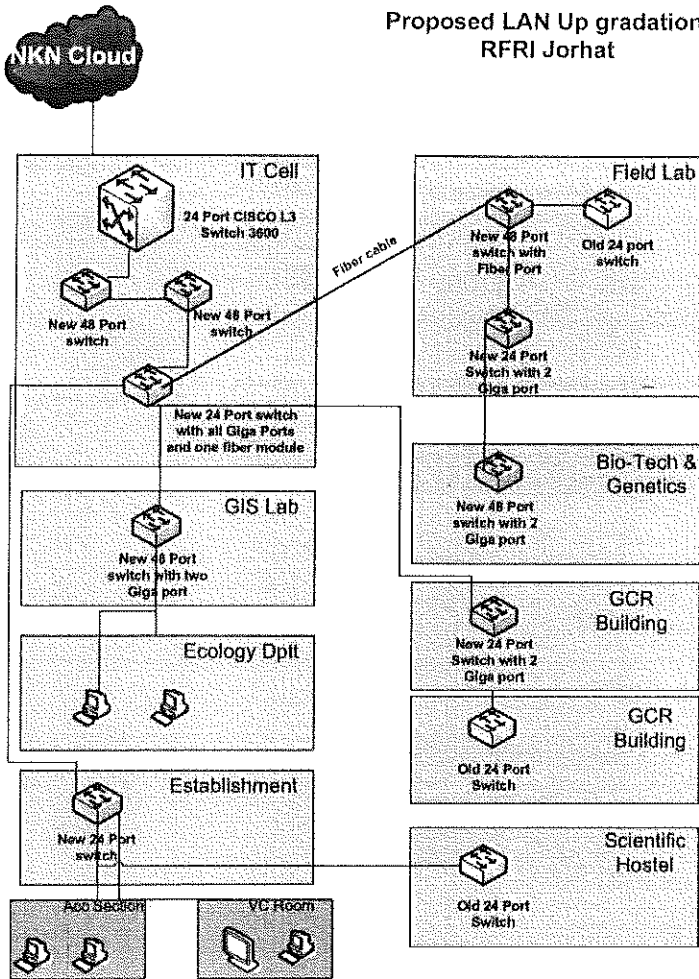

In IT- cell 4 24 port Dlink Switches will be replaced with 2 Nos. 48 Port switches. One 24 port dlink switch replaced with 1Nos. 24 port switch with all Giga port .

In GIS lab one 24 port switch replaced with 48 port switch with two Giga ports, which also connect Ecology Department.

In Establishment section 8 Port switch replaced with 24 port switch which also connect Account and VC room by removing 2 Nos 8 port switches in VC room and account sections.

In field lab one 24 port switch replaced with new 48 port switch, and two 8 port switches replaced with one new 24 port switch

In Bio Tech two old 24 port switches replaced with one new 48 port switch with 2 Giga Ports

In GCR Building one Dlink 24 port switches replaced with 1 new 24 port switches with two Giga ports

Note: All the uplinks between switches will be done with Giga ports only and UTP CAT-6 cable as Uplink media

David

(vii) Proposed LAN topology for IWST, Bangalore

Proposed LAN Up gradation. IWST

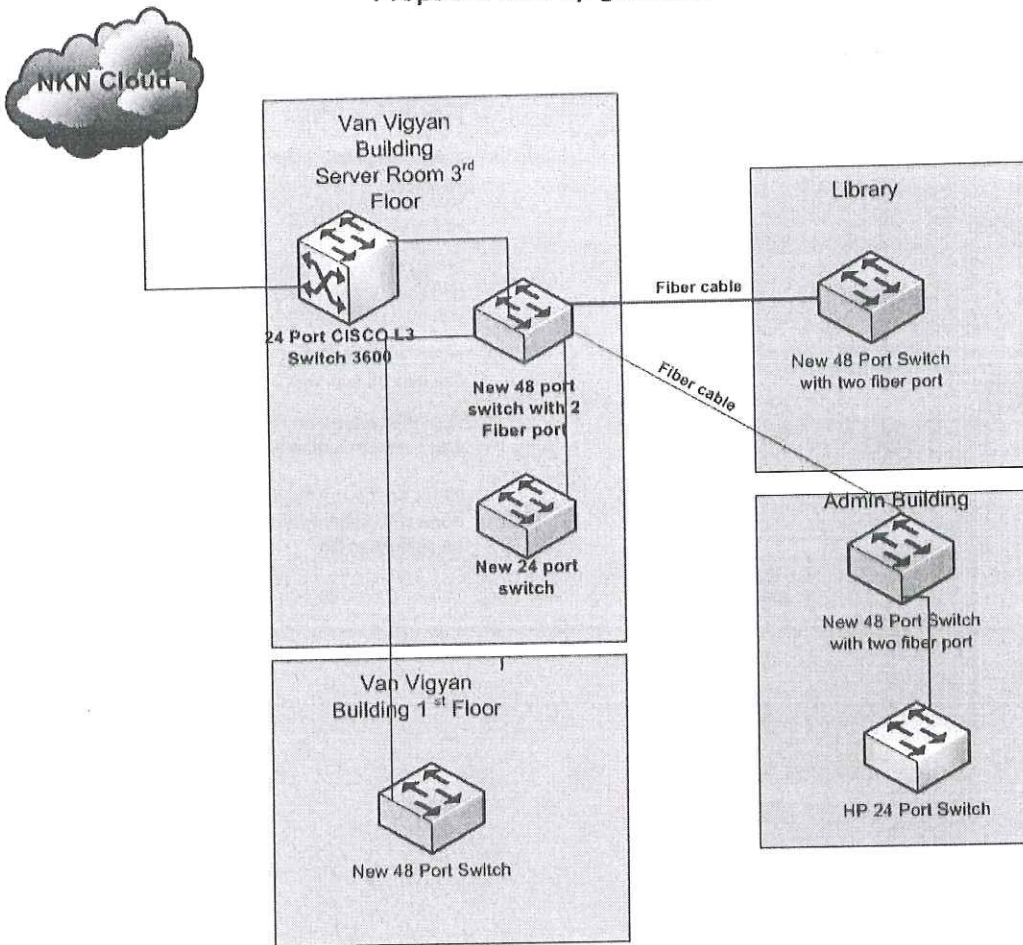

New one 48 port switch having 2 fiber port and one new 24 port switch added to Va Vigyan building 3rd floor by replacing old three 24 port switches

New one 48 Port switch added to Van Vigyan building first floor by replacing two old 24 port switches

New 48 Port Switch with two fiber ports added to Library by replacing the old 24 Port Switch

New 48 Port switch with two fiber ports added in the Admin building by replacing the old 24 Port switch. Also, another old 24 Port HP switch is replaced by an existing 24 Port HP switch which is currently installed at Library



Handwritten signature
 P.O. Bangalore
 P.O. Bangalore

(viii) Proposed LAN topology for FRI, Dehradun

FRI-LAN TOPOLOGY (A)

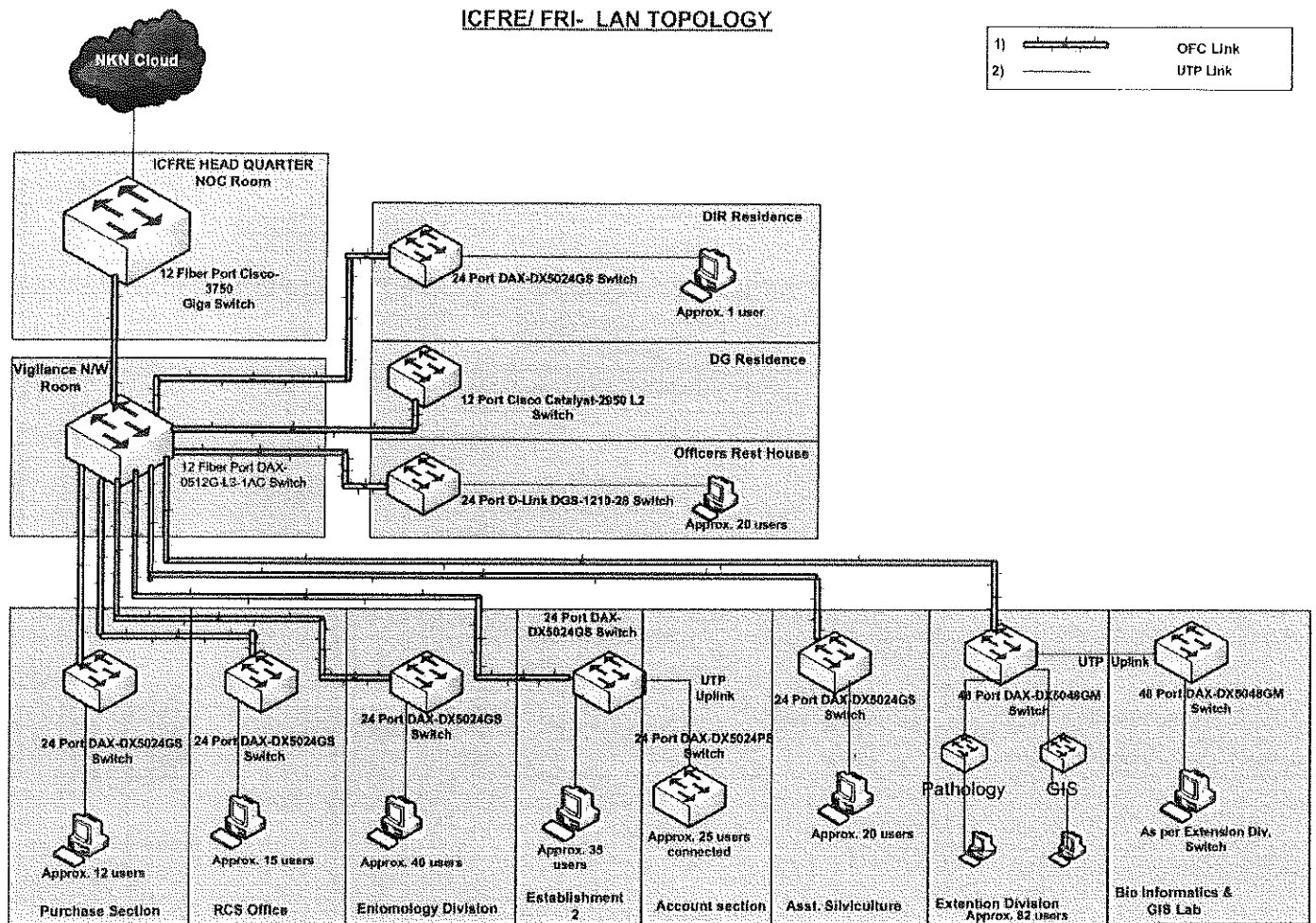

Contd.....

Bard

FRI-LAN TOPOLOGY B

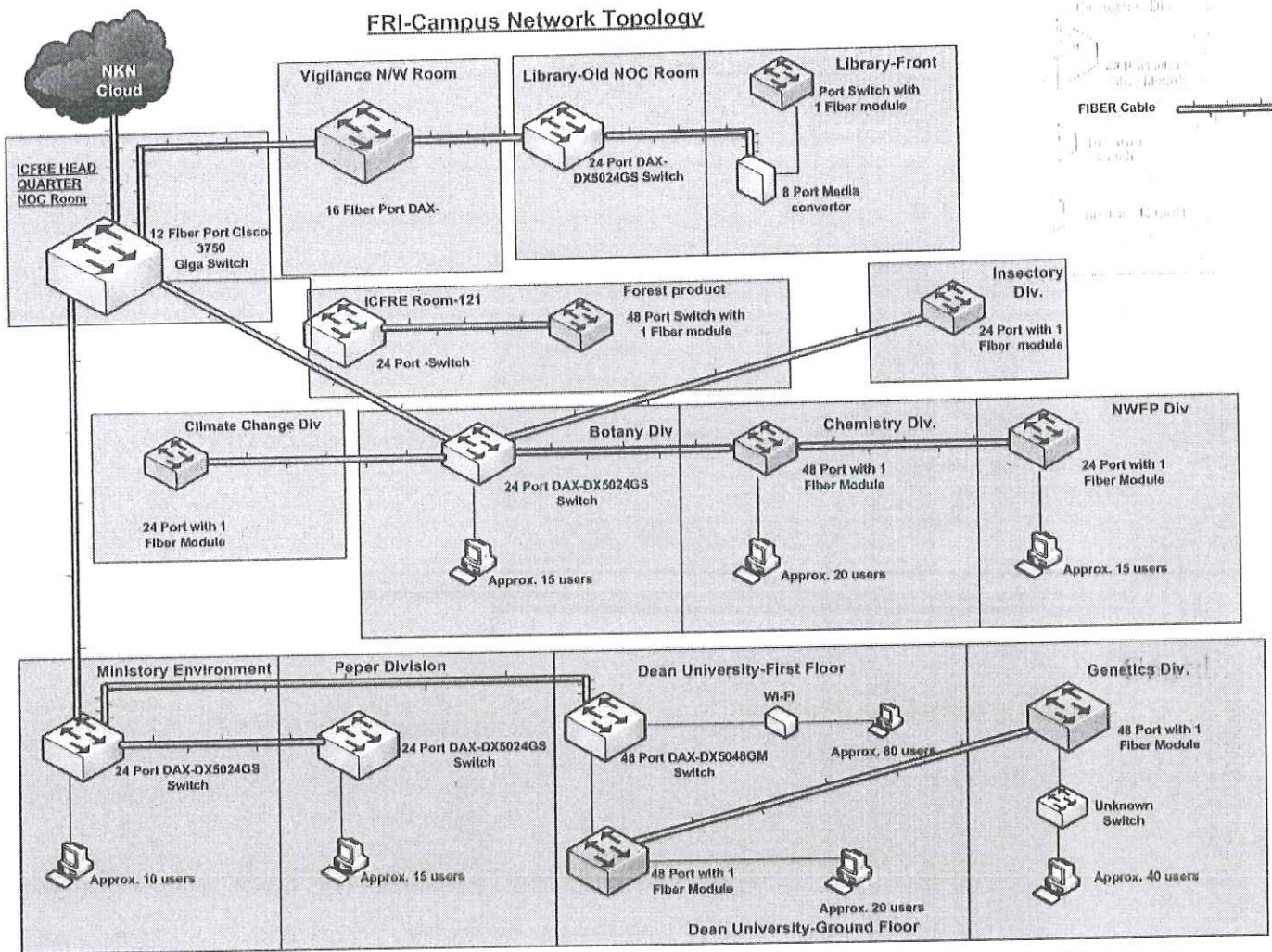

Contd.....

David
 Assistant Professor
 Department of Computer Science
 Anna University, Chennai

FRI LAN TOPOLOGY -C

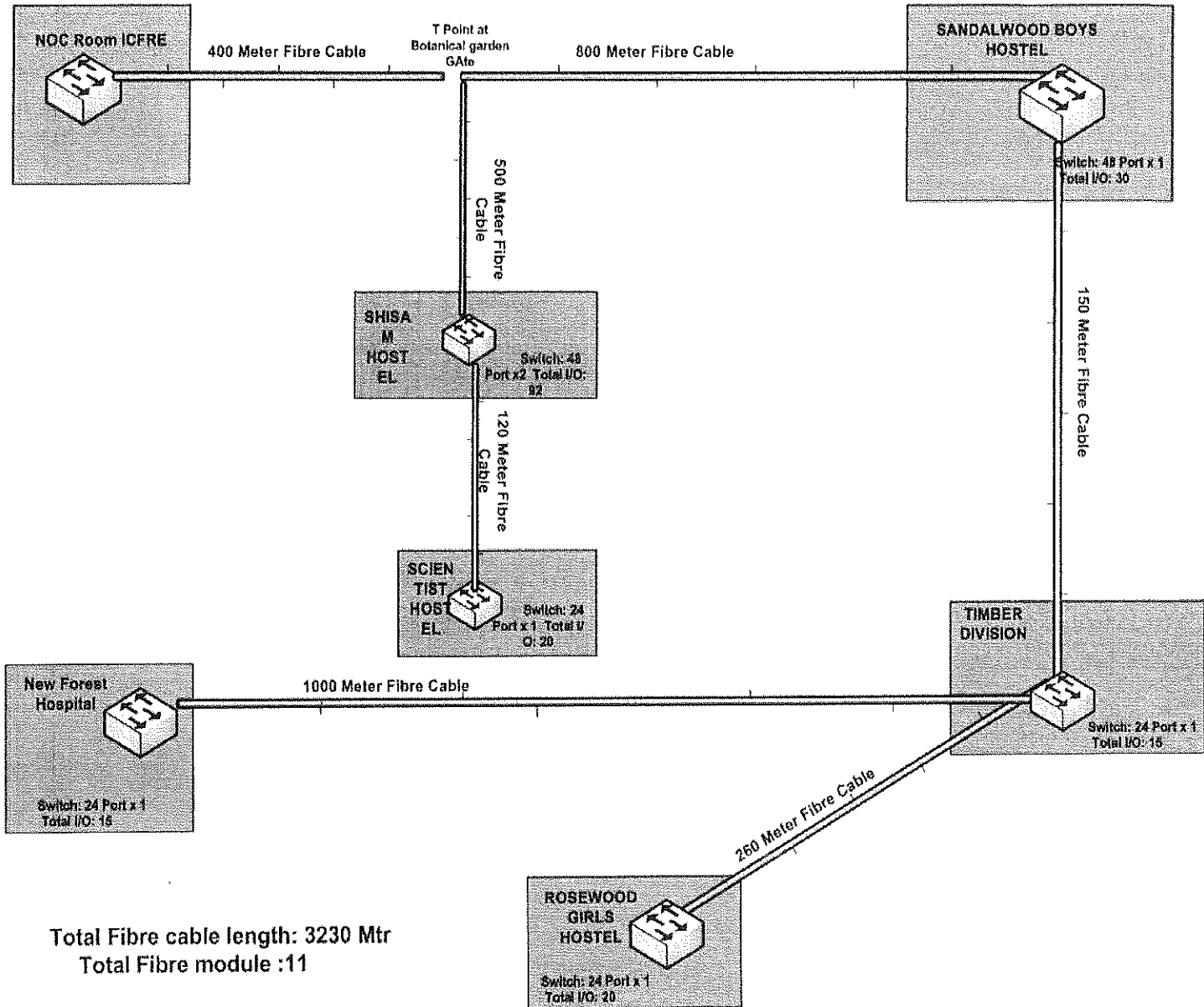

David

(i) Proposed LAN topology for TFRI, Jabalpur

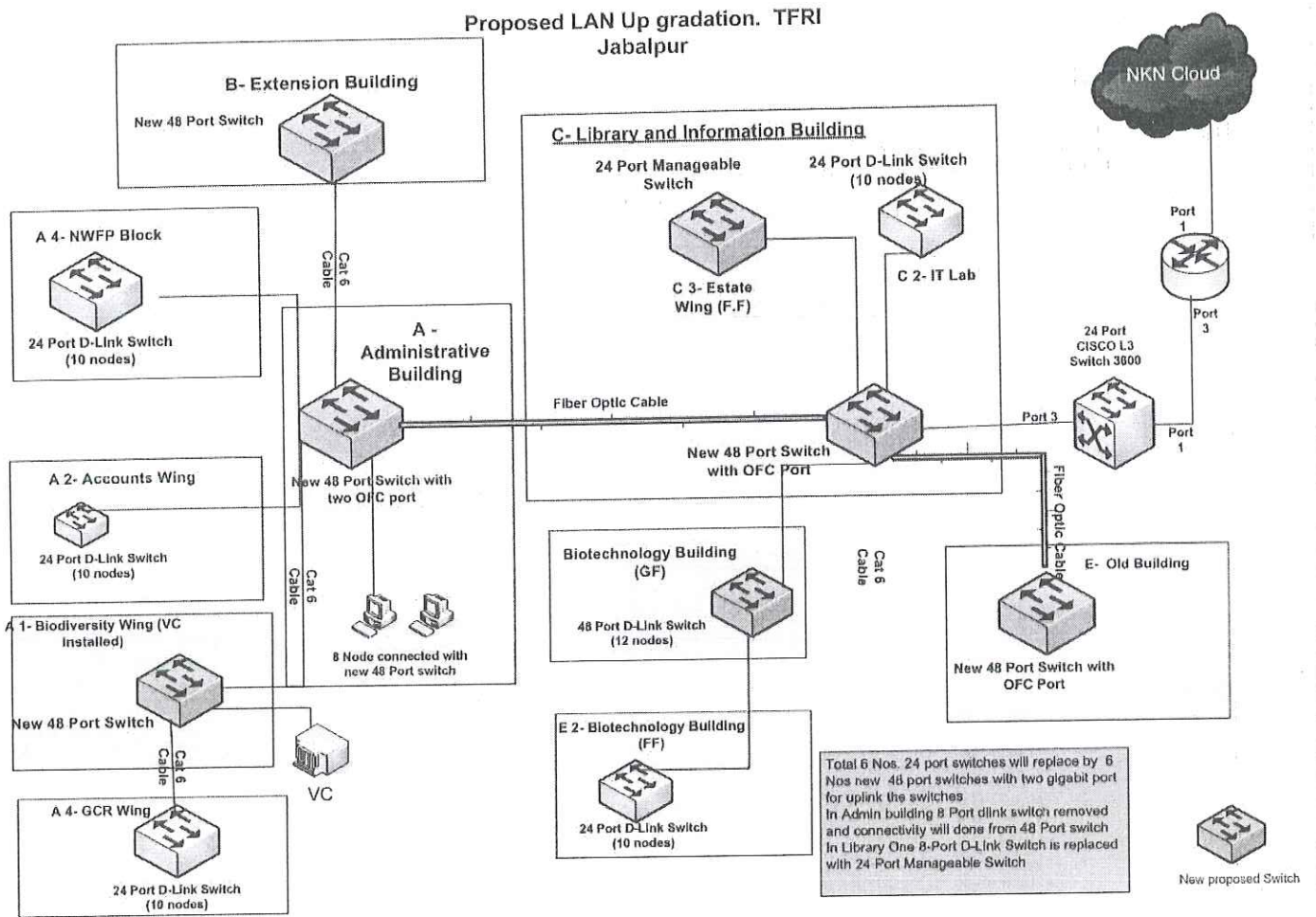

[Handwritten signature and official stamp]

II. LIST OF EQUIPMENT TO BE SUPPLIED FOR UPGRADATION OF LAN

#	Centers/Institutions	New Switches Added	Quantity of New 48 Port Switches	Quantity of New 24 Port Switches
1	HFRI, Shimla	48 Port switch (Base-T with 2 Giga ports) 24 Port switch (Base-T with 2 Giga ports)	1	2
2	IFGTB, Coimbatore	48 Port switch (Base-T with 2 Giga ports) 24 Port switch (Base-T with 2 Giga ports)	3	4
3	IFP, Ranchi	48 Port switch (Base-T with 2 Giga ports) 24 Port switch (Base-T with 2 Giga ports)	3	2
4	AFRI, Jodhpur	48 Port switch (Base-T with 2 Fiber ports) 48 Port switch (Base-T with 1 Fiber port) 48 Port switch (Base-T with 2 Giga ports) 24 Port switch (Base-T with 2 Giga ports)	1+1+1	3



5	RFRI, Jorhat	<p>48 Port switch (Base-T with 2 Giga ports)</p> <p>48 Port switch (Base-T with 1 Fiber port and 1 Giga port)</p> <p>24 Port switch (Base-T with all Giga ports and 1 Fiber module)</p> <p>24 Port switch (Base -T with 2 Giga ports)</p>	4+1	2+2
6	IWST, Bangalore	<p>48 Port switch (Base-T with 2 Fiber ports)</p> <p>48 Port switch (Base-T with 2 Giga ports)</p> <p>24 Port switch (Base-T with 2 Giga ports)</p>	3+1	1
7	TFRI, Jabalpur	<p>48 Port switch (Base-T with 2 Fiber ports)</p> <p>48 Port switch (Base-T with 1 Fiber port and 2 Giga ports)</p> <p>48 Port switch (Base-T with 2 Giga port)</p>	1+2+3	5

(Handwritten Signature)
 (Official Stamp)
 P.O. - ...

		24 Port switch (Base-T with 2 Giga ports)		
8	FRI, Dehradun	48 Port switch (Base-T with 2 Fiber ports) 16 Port L3 switch with 2 Fiber Ports 24 Port switch (Base-T with 2 Giga ports) 24 Port switch (Base-T with 2 Fiber ports)	6 + 1 (16 Port)	1+5
9	ICFRE, Dehradun	48 Port switch (Base-T with 2 Giga ports) 24 Port switch (Base-T with 2 Giga ports) 12 Port Switch (base-T with 2 Giga Ports)	4	4+1 (12 port)

Pawal

I. LIST OF EQUIPMENT TO BE CONSIDERED FOR MAINTENANCE

Note: - The list of equipment mentioned under Schedule VI-A has to be added for maintenance along with the list of items given in the table below. Therefore, the financial proposal for Cost of Comprehensive Maintenance Contract of Equipment is to be submitted accordingly.

#	Centers/Institutions	Existing Switches	Date of Purchase/ Installation
1	HFRI, Shimla	1 Nos # 24 Port Cisco WS Switch 3560X 1 Nos # 24 Port switch	21/01/2013* 2010
2	IFGTB, Coimbatore	1 Nos # 24 Port Cisco WS Switch 3560X 3 Nos # 24 Port switch	06/02/2013* 2010
3	IFP, RANCHI	1 Nos # 24 Port Cisco WS Switch 3560X 2 Nos # 24 Port switch	30/07/2013* 2013
4	AFRI, Jodhpur	1 Nos # 24 Port Cisco WS Switch 3560X 1 Nos # 24 Port D-Link Switch	11/01/2013* 2012
5	RFRI, Jorhat	1 Nos # 24 Port Cisco WS Switch 3560X 3 Nos # 24 Port switch	22/01/2013* 2011
6	IWST, Bangalore	1 Nos # 24 Port Cisco L3 Switch 3560X 1 Nos # 24 Port HP switch	21/01/2013*
7	TFRI, Jabalpur	1 Nos # 24 Port Cisco WS Switch 3560X 1 No # 24 Port switch	15/03/2013*

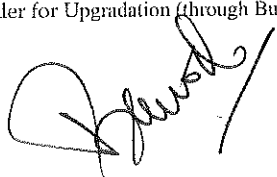

8	FRI, Dehradun	3 Nos # 24 Port D-link switch	2015
		11 Nos # 24 Port Dax switch	2011
		1 Nos # 12 Port Cisco Catalyst - 2950 switch	2005
9	ICFRE, Dehradun	1 Nos # 24 Port Cisco WS-C3560X	04/01/2012*
10	IFB, Hyderabad	1 Nos # 24 Port Cisco WS-C3560X	24/01/2013*
		2 Nos # D-Link	
11	CSFER, Allahabad	1 Nos # 24 Port Cisco WS-C3560X	28/01/2013*
12	Shore Laboratory, Vishakhapatnam	1 Nos # 24 Port Cisco WS-C3560X	11/07/2013*
14	ARCRBR, Aizawal	1 Nos # 24 Port Cisco WS-C3560X	30/07/2013*

*These switches are under 5 years warranty from the date of installation and shall be included in the maintenance contract thereafter.

David

I. LIST OF SWITCHES TO BE REPLACED UNDER BUYBACK

#	Centers/Institute	Existing Switch Details	Date of Purchase/Installation
1	HFRI, Shimla	3 Nos # 24 Port switch 2 Nos # 8 Port switch	2008 2008
2	IFGTB, Coimbatore	9 Nos # 24 Port switch	2002
3	IFP, RANCHI	2 Nos # DLink 1016D switch 9 Nos # 8 Port Hub	-
4	AFRI, Jodhpur	4 Nos # 24 Port switch 2 Nos # 16 Port switch	2009 -
5	RFRI, Jorhat	10 Nos # 24 Port switch 5 Nos # 8 Port switch	2010 2011
6	IWST, Bangalore	8 Nos # 24 Port switch	2008
7	TFRI, Jabalpur	10 Nos # 24 Port switch 1 Nos # 8 Port switch	2008
8	ICFRE, Dehradun	3 Nos # 48 Port switch 5 Nos # 24 Port switch 1 No#12 port switch	2005 2009 2005
8	FRI, Dehradun	1 Nos # 8 Port switch 1 Nos # 8 Port Media Converter 7 Nos # 24 Port switch 1 Nos # 48 Port switch 1 Nos # 12 Port switch 1 Nos # 12 Fiber Port Dax 0512G L3 Switch	2011

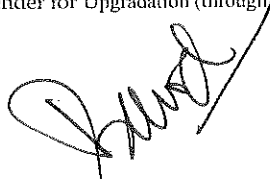

LIST OF LOCATIONS WITH DETAILED ADDRESS

Coordinating and Nodal Agency
Information Technology Division
Directorate of Administration
Indian Council of Forestry Research & Education
P.O. New Forest, Dehradun

List of ICFRE's Institutes	
1	Director Forest Research Institute P.O. New Forest Dehra Dun - 248 006 (Uttaranchal) e-mail : dir_fri@icfre.org
2	Director Institute of Forest Genetics & Tree Breeding Post Box No.1061 HPO R.S. Puram Coimbatore - 641 002 (Tamil Nadu) e-mail : dir_ifgtb@icfre.org
3	Director Institute of Wood Science & Technology Forest Research Laboratory Campus P.O. Malleswaram Bangalore - 560 003 (Karnataka) e-mail : dir_iwst@icfre.org
4	Director Tropical Forest Research Institute Mandla Road Jabalpur - 482 021 (M.P.) e-mail : dir_tfri@icfre.org
5	Director Himalayan Forest Research Institute "Conifer Campus", Panthaghathi Shimla - 171 009 (H.P.) e-mail : dir_hfri@icfre.org
6	Director Institute of Forest Productivity "Aranyodaya" P.O. : A.T.E., Lal Gutwa, via Piska Nagri Ranchi - 835 303 (Jharkhand) e-mail : dir_ifp@icfre.org
7	Director Rain Forests Research Institute Deovan, Post Box No.136, A.T. Road (East) Jorhat - 785 001 (Assam) e-mail : dir_rfri@icfre.org
8	Director Arid Forest Research Institute P.O. Krishi Mandi, New Pali Road Jodhpur - 342 005 (Rajasthan) e-mail : dir_afri@icfre.org
9	Director Institute of Forest Biodiversity (IFB) Dulapally, P.O. Hakimpet Hyderabad - 500 014 (A.P.) e-mail : director_ifb@icfre.org
List of ICFRE's Centres	
1	Director Centre for Social Forestry and Eco- rehabilitation, Allahabad 3/1, Lajpat Rai Road, New Katra, Allahabad-211002 email: dir_csfer@icfre.org
2	Director Advanced Research Centre for Bamboo & Rattan P.B. No. 171, Kulikawan Aizwal - 796001 (Mizoram)
3	Officer-in-Charge Wood Biodegradation Centre (Marine), Via Yoga Village, Beach Road, Andhra University Post, Visakhapatnam-530 003, Andhra Pradesh, India



LOCATION WISE REQUIREMENT OF SUPPORT TYPE

Coordinating and Nodal Agency
 Information Technology Division
 Directorate of Administration
 Indian Council of Forestry Research & Education
 P.O. New Forest, Dehradun

Sl.	Name of Institution	Required support
1	Forest Research Institute Dehra Dun - 248 006 (Uttaranchal)	One Resident Engineer
2	Institute of Forest Genetics and Tree Breeding Coimbatore - 641 002 (Tamil Nadu)	One Resident Engineer
3	Institute of Wood Science & Technology Bangalore - 560 003 (Karnataka)	One Resident Engineer
4	Tropical Forest Research Institute Jabalpur - 482 021 (M.P.)	One Resident Engineer
5	Himalayan Forest Research Institute Shimla - 171 009 (H.P.)	One Resident Engineer
6	Institute of Forest Productivity Ranchi - 835 303 (Jharkhand)	One Resident Engineer
7	Rain Forests Research Institute Jorhat - 785 001 (Assam)	One Resident Engineer
8	Arid Forest Research Institute Jodhpur - 342 005 (Rajasthan)	One Resident Engineer
9	Centre for Social Forestry & Eco-Rehabilitation Allahabad - 211 002 (U.P.)	Call Basis Technical Support
10	Institute of Forest Biodiversity (IFB) Hyderabad - 500 014 (A.P.)	Call Basis Technical Support
11	Advanced Research Centre for Bamboo & Rattan Aizwal - 796001 (Mizoram)	Call Basis Technical Support
12	Wood Biodegradation Centre (Marine), Visakhapatnam-530 003, Andhra Pradesh, India	Call Basis Technical Support

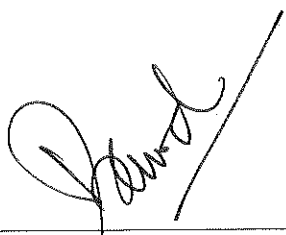

**LOCATION WISE ADDRESS AND CONTACT DETAILS OF
FAULT REPAIRING / SUPPORT CENTRE
TO BE PROVIDED BY THE FIRM**

Sl.	ICFRE Location	Address and Contact details of Fault Repairing Centre of the Firm
1	Dehra Dun (Uttarakhand)	
2	Coimbatore (Tamil Nadu)	
3	Bangalore (Karnataka)	
4	Jabalpur (M.P.)	
5	Jorhat (Assam)	
6	Jodhpur (Rajasthan)	
7	Shimla (H.P.)	
8	Ranchi (Jharkhand)	
9	Allahabad (U.P.)	
10	Hyderabad (A.P.)	
11	Aizwal (Mizoram)	
12	Visakhapatnam (AP)	

Signature of Bidder :

Name :

Seal :

Date :

Place :

Tender for Upgradation (through Buyback), operation and maintenance of existing & upgraded Local Area Network (LAN) hardware/software for five years #

David

Asst. Manager
Tender Enquiry
Muzaffarpur

Financial Proposal For Upgradation (through Buyback), operation and maintenance of existing & upgraded Local Area Network (LAN) hardware/software for five years

The financial bid should be in a separate
"Cover 2"
PART-I

Note: - The list of equipment includes the items to be supplied as per Schedule VI-A and the existing network equipment to be used as per Schedule VI-B.

Schedule IX-A

I. Cost for Upgradation of LAN Switches

#	Centers/Institute	New Switches Added	Quantity of New 48 Port Switches added	Quantity of New 24 Port Switches added	Total Cost of New Switches added (A) Rs	Existing Switches under buyback	Buy Back Price offered for existing Switches under buyback (B) (Rs)	Net Cost of Switches to ICFRE (A - B) (Rs)
1	HFERI, Shimla	48 Port switch (Base-T with 2 Giga ports) 24 Port switch (Base-T with 2 Giga ports)	1	2		3 Nos # 24 Port switch 2 Nos # 8 Port switch		
2	IFGTB, Coimbatore	48 Port switch (Base-T with 2 Giga ports) 24 Port switch (Base-T with 2 Giga ports)	3	4		9 Nos # 24 Port switch		

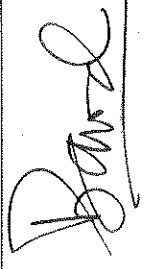

#	Centers/Institute	New Switches Added	Quantity of New 48 Port Switches added	Quantity of New 24 Port Switches added	Total Cost of New Switches added (A) Rs	Existing Switches under buyback	Buy Back Price offered for existing Switches under buyback (B) (Rs)	Net Cost of Switches to ICFRE (A - B) (Rs)
3	IFP, RANCHI	48 Port switch (Base-T with 2 Giga ports) 24 Port switch (Base-T with 2 Giga ports)	3	2		9 Nos # 8 Port Hub 2 Nos # DES 1016D switch		
4	AFRI, Jodhpur	48 Port switch (Base-T with 2 Fiber ports) 48 Port switch (Base-T with 1 Fiber port) 48 Port switch (Base-T with 2 Giga ports)	1+1+1	3		4 Nos # 24 Port switch 2 Nos # 16 Port switch		
5	RFRI, Jorhat	24 Port switch (Base-T with 2 Giga ports) 48 Port switch (Base-T with 2 Giga ports)	4+1	2+2		10 Nos # 24 Port switch		

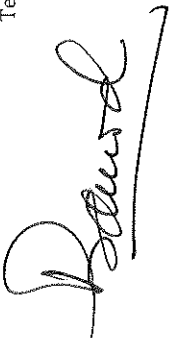

#	Centers/Institute	New Switches Added	Quantity of New 48 Port Switches added	Quantity of New 24 Port Switches added	Total Cost of New Switches added (A) Rs	Existing Switches under buyback	Buy Back Price offered for existing Switches under buyback (B) (Rs)	Net Cost of Switches to ICFRE (A - B) (Rs)
		48 Port switch (Base-T with 1 Fiber port and 1 Giga port)				5 Nos # 8 Port switch		
		24 Port switch (Base-T with all Giga ports and 1 Fiber module)						
		24 Port switch (Base-T with 2 Giga ports)						
6	IWST, Bangalore	48 Port switch (Base-T with 2 Fiber ports)	3+1	1		8 Nos # 24 Port switch		

Tender for Upgradation (through Buyback), operation and maintenance of existing & upgraded Local Area Network (LAN) hardware/software for five years # 48



#	Centers/Institute	New Switches Added	Quantity of New 48 Port Switches added	Quantity of New 24 Port Switches added	Total Cost of New Switches added (A) Rs	Existing Switches under buyback	Buy Back Price offered for existing Switches under buyback (B) (Rs)	Net Cost of Switches to ICFRE (A - B) (Rs)
		24 Port switch (Base-T with 2 Giga ports) 12 SFP Port L3 switch				3 Nos # 48 Port switch 1 Nos # 12 Port switch		
Total Cost for Upgradation of LAN Switches,								
Rs.....								

II. Cost of Network Component

#	Hardware	Quantity	Unit Rate (Rs)	Taxes (%)	Total Cost (Rs)
1	Fiber Module	16			
2	6 U Wall Mount Network Rack	11			
3	Patch Panel 24 port	10			
4	Patch Panel 48 port	10			
Total Cost of Network Hardware					

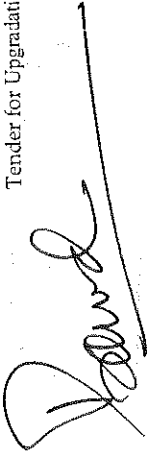

III. Operations & Maintenance Cost of LAN for 5 Years

#	Items	Year 1 (Rs)	Year 2 (Rs)	Year 3 (Rs)	Year 4 (Rs)	Year 5 (Rs)
1	Cost of Comprehensive Maintenance of Network Equipments (without taxes etc.)					
2	Cost of Operation and Maintenance of Network Services (without taxes etc.)					
					Total Cost for Operations & Maintenance of LAN for 5 Years (Rs)	

Therefore, Total financial Bid Value (Total Cost for Upgradation of LAN Switches + Cost of Network Component+ Total Cost for Operations & Maintenance of LAN for 5 Years) is (Rupees _____)

Note :

1. TDS shall be made as per Income Tax Rules.
2. The currency is Indian Rupees only.
3. The Assistant Director General (IT&FS), ICFRE shall have with him the power of addition and exclusion of network equipment in the Maintenance Contract, at the start of each quarter, as and when required, under intimation to all concerned. The quarterly payment shall be made on the basis of actual equipment maintained and any withdrawal / addition of equipment shall be given due consideration and the payment adjusted accordingly.

Signature of Bidder :

Name :

Seal :

Order for Upgradation (through Buyback), operation and maintenance of existing & upgraded Local Area Network (LAN) hardware/software for five years # 52

#	Centers/Institute	New Switches Added	Quantity of New 48 Port Switches added	Quantity of New 24 Port Switches added	Total Cost of New Switches added (A) Rs	Existing Switches under buyback	Buy Back Price offered for existing Switches under buyback (B) (Rs)	Net Cost of Switches to ICFRE (A - B) (Rs)
		48 Port switch (Base-T with 2 Giga ports) 24 Port switch (Base-T with 2 Giga ports)						
7	TFRl, Jabalpur	48 Port switch (Base-T with 2 Fiber ports) 48 Port switch (Base-T with 1 Fibre port and 2 Giga ports) 48 Port switch (Base-T with 2 Giga port) 24 Port switch (Base-T with 2 Giga ports)	1+2+3	5		10 Nos # 24 Port switch 1 No # 8 Port switch		

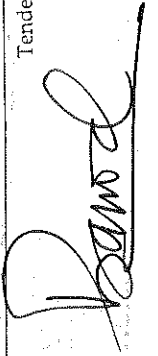

#	Centers/Institute	New Switches Added	Quantity of New 48 Port Switches added	Quantity of New 24 Port Switches added	Total Cost of New Switches added (A) Rs	Existing Switches under buyback	Buy Back Price offered for existing Switches under buyback (B) (Rs)	Net Cost of Switches to ICFRE (A - B) (Rs)
8	FRI, Dehradun	48 Port switch (Base-T with 2 Fiber ports) 16 SFP Port L3 switch 24 Port switch (Base-T with 2 Giga ports) 24 Port switch (Base-T with 2 Fiber ports)	6 +1	1 +5		1 Nos # 8 Port switch 1 Nos # 8 Port Media Converter 7 Nos # 24 Port switch 1 Nos # 48 Port switch 1 Nos # 12 Port switch		
9	ICFRE, Dehradun	48 Port switch (Base-T with 2 Giga ports)	4	4 +1		5 Nos # 24 Port switch		

Tender for Upgradation (through Buyback), operation and maintenance of existing & upgraded Local Area Network (LAN) hardware/software for five years # 50



1. Annexure 1 – Specification for newly proposed switches

Criteria	A. Specifications for 24 Port Managed Switch	Compliance (Yes/No)
Technical capability	50 Gbps or higher switching capacity	
	40 Mpps or higher forwarding performance	
	Non, blocking, wire speed architecture	
	Configurable up to 8000 MAC addresses, 1000 VLAN, IPv6 ready from Day 1	
Management	SNMP V2/V3 ,SSHv2, Telnet, CLI and web based interface	
Security	Port based ACL, DHCP snooping IPv4 & IPv6, Port Security, spanning tree Root Guard, BPDU guard, Route Advertisement validation to control unwanted Route Advertisements	
Standards	IEEE 802.1x IEEE 802.3x full duplex on 10BASE-T and 100BASE-TX ports IEEE 802.1D Spanning-Tree Protocol IEEE 802.1p class-of-service (CoS) Prioritization IEEE 802.1Q VLAN IEEE 802.1s IEEE 802.1w IEEE 802.3, 802.3ad, 802.3ab, 802.3z IEEE 802.3u	
Interfaces	24 Ports 10/100/1000 Mbps Uplink Port: should have 4 SFP Based uplink ports"	
Power	100 - 240 VAC, 50/60 Hz	
OEM	NDPP/EAL certified/OEM shall be in Gartner Leader Quadrant	

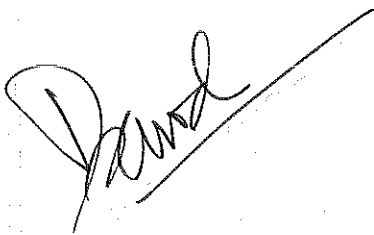

Criteria	B. Specifications for 48 Port Managed Switch	Compliance (Yes/No)
Technical capability	100 Gbps or higher switching capacity	
	70 Mpps or higher forwarding performance	
	Non, blocking, wire speed architecture	
	Configurable up to 8000 MAC addresses, 1000 VLAN, IPv6 ready from Day 1	
Management	SNMP V2/V3 ,SSHv2, Telnet, CLI and web based interface	
Security	Port based ACL, DHCP snooping IPv4 &IPv6, Port Security, spanning tree Root Guard, BPDU guard, Route Advertisement validation to control unwanted Route Advertisements	
Standards	IEEE 802.1x IEEE 802.3x full duplex on 10BASE-T and 100BASE-TX ports IEEE 802.1D Spanning-Tree Protocol IEEE 802.1p class-of-service (CoS) Prioritization IEEE 802.1Q VLAN IEEE 802.1s IEEE 802.1w IEEE 802.3, 802.3ad, 802.3ab, 802.3z IEEE 802.3u	
Interfaces	48 Ports 10/100/1000 Mbps Uplink Port: should have 4 SFP Based uplink ports"	
Power	100 - 240 VAC, 50/60 Hz	
OEM	NDPP/EAL certified/OEM shall be in Gartner Leader Quadrant	

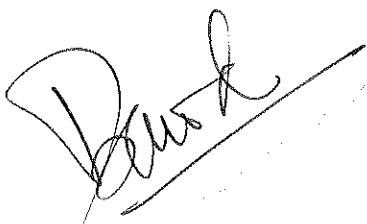

SNo	Details of Qualifying Document	Compliant (Yes/No)	Page No
1	Tender Fee:		
2	EMD		
3	Documentary proof of having authorization from Original Equipment Manufacturer (OEM)		
4	Compliance to the specifications of the equipment given in the Annexures 1 and 2 with supporting documents.		
5	The bidder should be a firm registered under Companies Act, 1956 / 2013 for the last five years.		
6	The firm should have minimum annual turnover of Rs. 50 Crore during the last three financial years. The annual turnover and P&L statements certified by a qualified Chartered Accountant are to be submitted.		
7	Existing Staff Strength of the firm, certified by the HR Head of the firm.		
8	Copy of Firm's Registration / Partnership Deed / Power of Attorney.		
9	Proof of Sales Tax / VAT / Income Tax Registration and proof of Sales Tax/ VAT/Service Tax paid for the latest assessment year.		
10	PAN/TAN allotted to the company by the Income Tax Department.		
11	Clearance certificate from Income Tax department for last financial /assessment year or Income Tax Returns.		
12	Authorisation for signing the tender documents/bids.		
13	Particulars of the Firm as per Schedule III.		
14	Bid Proposal Sheet as per Schedule IV.		
15	Location wise Address and Contact Details of Fault Repairing Centre to be provided by the firm as per Schedule VIII.		

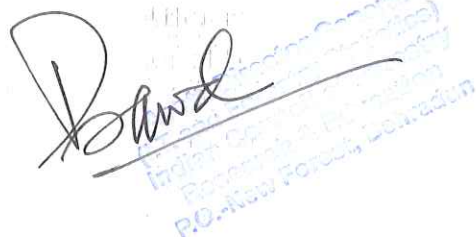

SNo	Details of Technical Document	Compliant (Yes/No)	Page No
1	The composition of the proposed staff/team to be engaged, the task, which would be assigned to each, and their timing.		
2	Curriculum Vitae (C.V.) of proposed key staff as per Schedule I, with dully recent photograph by the proposed key professional and the document signed by authorized signatory. Key information should include: year with the firm, and degree of responsibility held in various similar assignments during the last 2 (two) years. Key professional staff of permanent nature possessing certifications of management/maintenance of networking hardware with sufficient experience shall be given preference.		
3	Assignment of similar nature and magnitude successfully completed during last three years as per Schedule II. Enclose copies in work order and documents in support of rendering satisfactory services of the assignments detailed in the schedule. Similar assignments undertaken in Government Organisations shall be given preference during evaluation.		
4	Certificate to the effect of having adequate Test and Measuring Instruments available on hand (own) and proposed to be inducted (own & hired to be given separately) for the subject work.		
5	A Certificate to the effect that the company is in the business of Supply, Installation, Commissioning and Maintenance of Networking Equipment and Hardware for last five financial years with relevant documentary proof.		
6	Completed particulars as per the Performa given in Schedule VIII.		
7	Declaration in respect of Non-black listing of the firm.		
8	Any other documents in support of technical details.		
9	This tender document duly sealed and signed by the authorized signatory on every page and enclosed.		

